

ISSN 2518-170X (Online),
ISSN 2224-5278 (Print)

ҚАЗАҚСТАН РЕСПУБЛИКАСЫ
ҰЛТТЫҚ ҒЫЛЫМ АКАДЕМИЯСЫНЫҢ
Satbayev University

Х А Б А Р Л А Р Ы

ИЗВЕСТИЯ

НАЦИОНАЛЬНОЙ АКАДЕМИИ НАУК
РЕСПУБЛИКИ КАЗАХСТАН
Satbayev University

NEWS

OF THE ACADEMY OF SCIENCES
OF THE REPUBLIC OF KAZAKHSTAN
Satbayev University

SERIES
OF GEOLOGY AND TECHNICAL SCIENCES

2 (440)

MARCH – APRIL 2020

THE JOURNAL WAS FOUNDED IN 1940

PUBLISHED 6 TIMES A YEAR

ALMATY, NAS RK

NAS RK is pleased to announce that News of NAS RK. Series of geology and technical sciences scientific journal has been accepted for indexing in the Emerging Sources Citation Index, a new edition of Web of Science. Content in this index is under consideration by Clarivate Analytics to be accepted in the Science Citation Index Expanded, the Social Sciences Citation Index, and the Arts & Humanities Citation Index. The quality and depth of content Web of Science offers to researchers, authors, publishers, and institutions sets it apart from other research databases. The inclusion of News of NAS RK. Series of geology and technical sciences in the Emerging Sources Citation Index demonstrates our dedication to providing the most relevant and influential content of geology and engineering sciences to our community.

Қазақстан Республикасы Ұлттық ғылым академиясы "ҚР ҰҒА Хабарлары. Геология және техникалық ғылымдар сериясы" ғылыми журналының Web of Science-тің жаңаланған нұсқасы Emerging Sources Citation Index-те индекстелуге қабылданғанын хабарлайды. Бұл индекстелу барысында Clarivate Analytics компаниясы журналды одан әрі the Science Citation Index Expanded, the Social Sciences Citation Index және the Arts & Humanities Citation Index-ке қабылдау мәселесін қарастыруда. Web of Science зерттеушілер, авторлар, баспашылар мен мекемелерге контент тереңдігі мен сапасын ұсынады. ҚР ҰҒА Хабарлары. Геология және техникалық ғылымдар сериясы Emerging Sources Citation Index-ке енуі біздің қоғамдастық үшін ең өзекті және беделді геология және техникалық ғылымдар бойынша контентке адалдығымызды білдіреді.

НАН РК сообщает, что научный журнал «Известия НАН РК. Серия геологии и технических наук» был принят для индексирования в Emerging Sources Citation Index, обновленной версии Web of Science. Содержание в этом индексировании находится в стадии рассмотрения компанией Clarivate Analytics для дальнейшего принятия журнала в the Science Citation Index Expanded, the Social Sciences Citation Index и the Arts & Humanities Citation Index. Web of Science предлагает качество и глубину контента для исследователей, авторов, издателей и учреждений. Включение Известия НАН РК. Серия геологии и технических наук в Emerging Sources Citation Index демонстрирует нашу приверженность к наиболее актуальному и влиятельному контенту по геологии и техническим наукам для нашего сообщества.

Б а с р е д а к т о р ы
э. ғ. д., профессор, ҚР ҰҒА академигі

И.К. Бейсембетов

Бас редакторының орынбасары

Жолтаев Г.Ж. проф., геол.-мин. ғ. докторы

Р е д а к ц и я а л қ а с ы:

Абаканов Т.Д. проф. (Қазақстан)
Абишева З.С. проф., академик (Қазақстан)
Агабеков В.Е. академик (Беларусь)
Алиев Т. проф., академик (Әзірбайжан)
Бакиров А.Б. проф., (Қырғызстан)
Беспәев Х.А. проф. (Қазақстан)
Бишимбаев В.К. проф., академик (Қазақстан)
Буктуков Н.С. проф., академик (Қазақстан)
Булат А.Ф. проф., академик (Украина)
Ганиев И.Н. проф., академик (Тәжікстан)
Грэвис Р.М. проф. (АҚШ)
Ерғалиев Г.К. проф., академик (Қазақстан)
Жуков Н.М. проф. (Қазақстан)
Қожахметов С.М. проф., академик (Қазақстан)
Конторович А.Э. проф., академик (Ресей)
Курскеев А.К. проф., академик (Қазақстан)
Курчавов А.М. проф., (Ресей)
Медеу А.Р. проф., академик (Қазақстан)
Мұхамеджанов М.А. проф., корр.-мүшесі (Қазақстан)
Нигматова С.А. проф. (Қазақстан)
Оздоев С.М. проф., академик (Қазақстан)
Постолатий В. проф., академик (Молдова)
Ракишев Б.Р. проф., академик (Қазақстан)
Сейтов Н.С. проф., корр.-мүшесі (Қазақстан)
Сейтмуратова Э.Ю. проф., корр.-мүшесі (Қазақстан)
Степанец В.Г. проф., (Германия)
Хамфери Дж.Д. проф. (АҚШ)
Штейнер М. проф. (Германия)

«ҚР ҰҒА Хабарлары. Геология және техникалық ғылымдар сериясы».

ISSN 2518-170X (Online),

ISSN 2224-5278 (Print)

Меншіктенуші: «Қазақстан Республикасының Ұлттық ғылым академиясы» РҚБ (Алматы қ.).

Қазақстан республикасының Мәдениет пен ақпарат министрлігінің Ақпарат және мұрағат комитетінде 30.04.2010 ж. берілген №10892-Ж мерзімдік басылым тіркеуіне қойылу туралы куәлік.

Мерзімділігі: жылына 6 рет.

Тиражы: 300 дана.

Редакцияның мекенжайы: 050010, Алматы қ., Шевченко көш., 28, 219 бөл., 220, тел.: 272-13-19, 272-13-18,
<http://www.geolog-technical.kz/index.php/en/>

© Қазақстан Республикасының Ұлттық ғылым академиясы, 2020

Редакцияның Қазақстан, 050010, Алматы қ., Қабанбай батыр көш., 69а.

мекенжайы: Қ. И. Сәтбаев атындағы геология ғылымдар институты, 334 бөлме. Тел.: 291-59-38.

Типографияның мекенжайы: «NurNaz GRACE», Алматы қ., Рысқұлов көш., 103.

Г л а в н ы й р е д а к т о р
д. э. н., профессор, академик НАН РК

И. К. Бейсембетов

Заместитель главного редактора

Жолтаев Г.Ж. проф., доктор геол.-мин. наук

Р е д а к ц и о н н а я к о л л е г и я:

Абаканов Т.Д. проф. (Казахстан)
Абишева З.С. проф., академик (Казахстан)
Агабеков В.Е. академик (Беларусь)
Алиев Т. проф., академик (Азербайджан)
Бакиров А.Б. проф., (Кыргызстан)
Беспаяев Х.А. проф. (Казахстан)
Бишимбаев В.К. проф., академик (Казахстан)
Буктуков Н.С. проф., академик (Казахстан)
Булат А.Ф. проф., академик (Украина)
Ганиев И.Н. проф., академик (Таджикистан)
Грэвис Р.М. проф. (США)
Ергалиев Г.К. проф., академик (Казахстан)
Жуков Н.М. проф. (Казахстан)
Кожаметов С.М. проф., академик (Казахстан)
Конторович А.Э. проф., академик (Россия)
Курскеев А.К. проф., академик (Казахстан)
Курчавов А.М. проф., (Россия)
Медеу А.Р. проф., академик (Казахстан)
Мухамеджанов М.А. проф., чл.-корр. (Казахстан)
Нигматова С.А. проф. (Казахстан)
Оздоев С.М. проф., академик (Казахстан)
Постолатий В. проф., академик (Молдова)
Ракишев Б.Р. проф., академик (Казахстан)
Сейтов Н.С. проф., чл.-корр. (Казахстан)
Сейтмуратова Э.Ю. проф., чл.-корр. (Казахстан)
Степанец В.Г. проф., (Германия)
Хамфери Дж.Д. проф. (США)
Штейнер М. проф. (Германия)

«Известия НАН РК. Серия геологии и технических наук».

ISSN 2518-170X (Online),

ISSN 2224-5278 (Print)

Собственник: Республиканское общественное объединение «Национальная академия наук Республики Казахстан (г. Алматы).

Свидетельство о постановке на учет периодического печатного издания в Комитете информации и архивов Министерства культуры и информации Республики Казахстан №10892-Ж, выданное 30.04.2010 г.

Периодичность: 6 раз в год.

Тираж: 300 экземпляров.

Адрес редакции: 050010, г. Алматы, ул. Шевченко, 28, ком. 219, 220, тел.: 272-13-19, 272-13-18,
<http://www.geolog-technical.kz/index.php/en/>

© Национальная академия наук Республики Казахстан, 2020

Адрес редакции: Казахстан, 050010, г. Алматы, ул. Кабанбай батыра, 69а.

Институт геологических наук им. К. И. Сатпаева, комната 334. Тел.: 291-59-38.

Адрес типографии: «NurNaz GRACE», г. Алматы, ул. Рыскулова, 103.

E d i t o r i n c h i e f

doctor of Economics, professor, academician of NAS RK

I. K. Beisembetov

Deputy editor in chief

Zholtayev G.Zh. prof., dr. geol-min. sc.

E d i t o r i a l b o a r d:

Abakanov T.D. prof. (Kazakhstan)
Abisheva Z.S. prof., academician (Kazakhstan)
Agabekov V.Ye. academician (Belarus)
Aliyev T. prof., academician (Azerbaijan)
Bakirov A.B. prof., (Kyrgyzstan)
Bespayev Kh.A. prof. (Kazakhstan)
Bishimbayev V.K. prof., academician (Kazakhstan)
Buktukov N.S. prof., academician (Kazakhstan)
Bulat A.F. prof., academician (Ukraine)
Ganiyev I.N. prof., academician (Tadjikistan)
Gravis R.M. prof. (USA)
Yergaliev G.K. prof., academician (Kazakhstan)
Zhukov N.M. prof. (Kazakhstan)
Kozhakhmetov S.M. prof., academician (Kazakhstan)
Kontorovich A.Ye. prof., academician (Russia)
Kurskeyev A.K. prof., academician (Kazakhstan)
Kurchavov A.M. prof., (Russia)
Medeu A.R. prof., academician (Kazakhstan)
Muhamedzhanov M.A. prof., corr. member. (Kazakhstan)
Nigmatova S.A. prof. (Kazakhstan)
Ozdoev S.M. prof., academician (Kazakhstan)
Postolatii V. prof., academician (Moldova)
Rakishev B.R. prof., academician (Kazakhstan)
Seitov N.S. prof., corr. member. (Kazakhstan)
Seitmuratova Ye.U. prof., corr. member. (Kazakhstan)
Stepanets V.G. prof., (Germany)
Humphery G.D. prof. (USA)
Steiner M. prof. (Germany)

News of the National Academy of Sciences of the Republic of Kazakhstan. Series of geology and technology sciences.

ISSN 2518-170X (Online),

ISSN 2224-5278 (Print)

Owner: RPA "National Academy of Sciences of the Republic of Kazakhstan" (Almaty).

The certificate of registration of a periodic printed publication in the Committee of information and archives of the Ministry of culture and information of the Republic of Kazakhstan N 10892-Ж, issued 30.04.2010.

Periodicity: 6 times a year.

Circulation: 300 copies.

Editorial address: 28, Shevchenko str., of. 219, 220, Almaty, 050010, tel. 272-13-19, 272-13-18,

<http://www.geolog-technical.kz/index.php/en/>

© National Academy of Sciences of the Republic of Kazakhstan, 2020

Editorial address: Institute of Geological Sciences named after K.I. Satpayev

69a, Kabanbai batyr str., of. 334, Almaty, 050010, Kazakhstan, tel.: 291-59-38.

Address of printing house: «NurNaz GRACE», 103, Ryskulov str, Almaty.

NEWS

OF THE NATIONAL ACADEMY OF SCIENCES OF THE REPUBLIC OF KAZAKHSTAN

SERIES OF GEOLOGY AND TECHNICAL SCIENCES

ISSN 2224-5278

Volume 2, Number 440 (2020), 55 – 62

<https://doi.org/10.32014/2020.2518-170X.31>**D. F. Goncharenko, A. Y. Aleinikova, A. V. Ubiivovk**

Kharkiv National University of Construction and Architecture, Kharkiv, Ukraine.
E-mail: gonch@kstuca.kharkov.ua, alevtynaal222@gmail.com, quartv@gmail.com

**DEVELOPMENT OF A REHABILITATION METHOD
FOR SEWER TUNNELS AT THE JUNCTIONS
TO INSPECTION SHAFTS**

Abstract. In the context of the underfunding of the sewer system sector and high depreciation of the distribution system for wastewater disposal, operating companies conduct their business at the limit of their technical and economic capabilities. The complexity of the operation of sewer tunnels resides in their non-repairability. Therefore, a promising area of research is to extend their durability through the development of alternative repair technologies from an economic point of view, which will ensure their smooth operation under conditions of limited funding. The findings of the research on the causes of failures in operation of sewer tunnels are presented. Using the expert evaluation method, it is found that the main cause of emergency situations is damage to the arched section of tunnels at their junctions to inspection shafts. A new method was developed for rehabilitating sewer tunnels in places where they adjoin inspection shafts using reinforced concrete rings with corrosion-resistant coating. A numerical simulation of the stress-strain state of the tunnel's reinforcement structure was performed. The expediency of the proposed method for rehabilitating sewer tunnels at their junctions to inspections shafts was presented and substantiated. Through the use of this method, the cost saving of financial resources for materials is tripled in comparison with other materials.

Key words: sewer tunnel, deterioration, inspection shaft, corrosion, rehabilitation method.

Introduction. As numerous cases of collapsed sewer tunnels have shown, concrete and reinforced concrete structures do not last for their guaranteed lifetime and frequently fail before their rated service life (20 to 30 years) [1,2]. In this case, the main cause of the collapses is the susceptibility of their arched section to the effects of biogenic corrosion. Particular attention, when considering the issue of rehabilitating the structures of sewer tunnels, requires to be paid to the corrosion of concrete and reinforced concrete structures, the widespread use of which has resulted in a situation where almost all the tunnels erected and put into operation since the early 1950s, are currently in disrepair [3].

The development of sewer system operating services under conditions of limited funding for the industry is aimed at increasing the durability of the distribution system by developing new technologies for their repair and rehabilitation, which will ensure its smooth operation at optimum cost-performance ratio. Furthermore, an increase in the amounts of rehabilitation work on sewer tunnels raises the requirements as regards the environmental safety of construction work during the operation and repair of distribution networks in the existing urban area conditions. Accordingly, this makes it necessary to use technical facilities that ensure work is carried out according to the most appropriate methods in terms of the cost-performance ratio [4,5].

It should be noted that in conditions of limited financial resources, additional attraction of financial resources due to foreign loans is necessary [6].

The search for rational methods for repairing tunnels is relevant in connection with the reform of Ukrainian environmental legislation to comply with environmental standards of the European Union [7].

This shows that the area of research on the development of rational methods for rehabilitating sewer tunnels is relevant.

Literature data analysis and setting of the problem. Comprehensive studies on operating reliability and trouble-free operation of wastewater pipelines of various diameters clearly show that

currently, preference is given to using trenchless technologies that are more cost-effective than traditional ones (open-cut involving excavation). The results of many years research on the cause-and-effect relationship of emergency situations in the pipelines of the water and sewage utilities are consolidated in the work [8], with particular attention paid to the impact of the technical condition of the system on the quality of provided services. The issue of rehabilitating sewer tunnels from precast reinforced concrete structures using multi-component building materials is considered in the work [8]. In the work [10], particular attention is paid to filling the annular space using trenchless technologies. In this case, a multicomponent mixture is used to reduce friction of surfaces and stabilize soils during the repair of utilities, in particular when using the Relining technology. Multifactor studies on using polyethylene pipes, polymer liners in the rehabilitation of pipelines over the course of their further operation are presented in the work [11]. It should be noted that the above-mentioned works describe quite comprehensively the issues related to the extension of the service life of utilities systems, while the lifetime of a sewer tunnel has its own peculiarities of maintaining smooth operation.

The study [12] illustrates in detail the point repair of linear sections of pipelines using Quick-Lock polymeric mechanical sleeves. Equally important is the environmental aspect of using “closed” technologies, especially when it is a case of sewer tunnels. The work [13] mentions an improvement in the environmental component of the use of trenchless technologies.

With the implementation of IT systems, more and more attention is paid to simulating the processes of repair and operation of pipelines. In order to predict the failure-free operation of utilities systems, an integrated model for smooth operation failure in distribution networks has been proposed [14]. Based on statistical data, it is possible to develop regression models that predict the operational and structural conditions for the functioning of pipelines [15].

In the context of the study of the influence of factors on the trouble-free service life of linear utilities systems, and the feasibility study of work performance indicators, it should be noted as follows:

- The research work [16] presents the results of a detailed study of the protection of reinforced concrete wastewater disposal networks against corrosion of different origin;
- The work [17] gives numerical indicators of longitudinal bending in pipelines exposed to lateral soil movements, which also plays an important role in the performance of construction work.

After reviewing the existing technologies of repair and rehabilitation of sewer networks [18-27], it may be concluded that the organizational and technological solutions for trenchless repair of large-diameter sewer networks of are being enhanced on an ongoing basis in order to improve the cost-performance ratio. In turn, it is relevant to study in detail the issue of the service life of large-diameter sewer tunnels, and to search for organizational and technological solutions to improve trouble-free operation.

Purpose and objectives of research. The purpose of this work is to develop and study a new method for rehabilitating sewer tunnels, which will allow it to be used in places where they adjoin inspection shafts, and to reduce the duration and energy consumption when carrying out rehabilitation work.

To achieve the purpose in view, the following tasks were defined:

- To investigate the causes of the collapse of sewer tunnels;
- By using expert evaluation to identify technical parameters affecting the trouble-free operation of large-diameter sewers;
- To develop a method for rehabilitating sewer tunnels in places where they adjoin inspection shafts;
- To obtain technical and economic results of the use of the proposed technology for sewer tunnel rehabilitation.

Investigation on the causes of failures in smooth operation of sewer tunnels. The investigation of the service life of sewer tunnels suggests that up to 80-90% of accidents in reinforced concrete pipelines are due to corrosion processes. As the analysis of emergencies in reinforced concrete sewer tunnels shows, the most critical areas of the wastewater disposal networks are areas in the vicinity of stilling pools or inspection shafts. Specifically, in 2018, an emergency failure occurred at the crossover section of the Main deep-laid sewer tunnel on Grekovskaya street in Kharkiv. The section of the collapse was located in the immediate vicinity of the stilling pool of wastewater streams (figure 1).

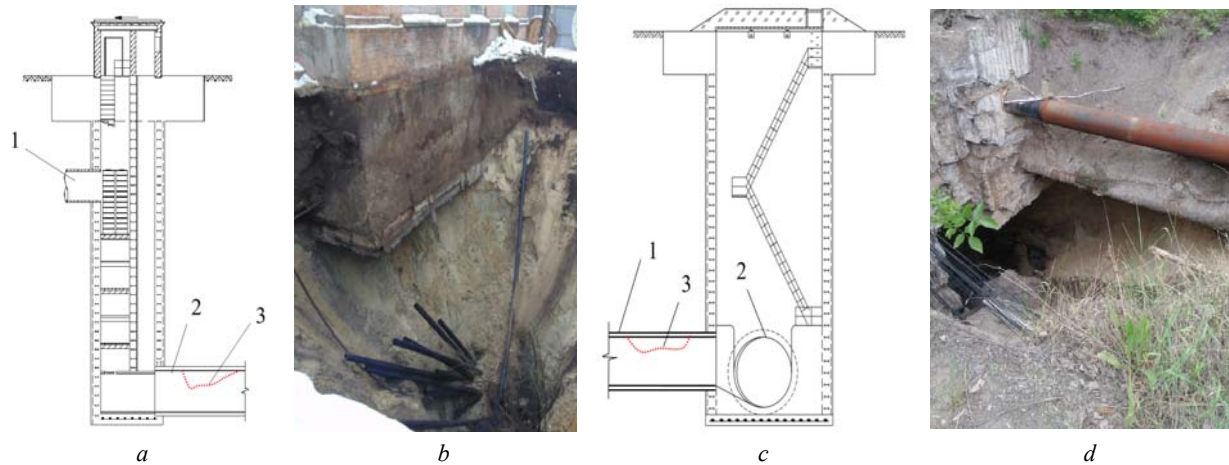

Figure 1 – Emergency failure of the sewer tunnel on Grekovskaya street (Kharkiv, Ukraine, 2017):

a – design solution of the stilling pool; *b* - the consequences of the accident;

c – design solution of the shaft; *d*- the consequences of the accident;

1 – sewer incoming into the stilling pool; 2 – arched sewer tunnel; 3 – the area of collapse

The main cause of the local collapse is damage to the reinforced concrete structure of the tunnel arch as a result of exposure to biogenic corrosion. The wastewater in the stilling pool falls from elevation 95.8 to the elevation of the invert of the drainage sewer tunnel of 83.9 ($H=11.9$ m). As a result of the segregation of the flow, sulfuric gas is extensively released, which in subsequent reactions is converted to sulfuric acid of a high degree of concentration. Without any anticorrosion protection, the concrete lining of the tunnel, which carries the load from the soil mass, is being deteriorated. Due to the disruption of the supporting arch structure, the ground rock was carried out into the tunnel body, followed by the collapse and sinking of the adjacent building. For similar reasons, the sewer tunnel collapsed in the area of the Kharkiv Tractor Plant in 2015-2016.

Based on the monitoring of the service life of sewer tunnels, the main causes of failures in smooth operation of distribution networks have been summarized. Each cause is assigned the symbol C1...C8 (table 1).

Table 1 – Causes of failures in smooth operation of sewer tunnels

Item No.	Failure cause
C1	Deterioration of the tunnel invert by aggressive factors
C2	Systematic increase in wastewater aggressivity
C3	Deterioration of the arched section of the sewer tunnel structure
C4	Technical condition of inspection shafts, stilling pools, chambers
C5	Variations in wastewater volumes
C6	Intensive excavation near the tunnel's route
C7	Deterioration of the arched section at the junctions to inspection shafts, stilling pools, shafts
C8	Drops in the invert's elevations according to the longitudinal profile

According to the expert evaluation method, the ranking of the causes of failures in smooth operation of sewer tunnels was performed [26]. When ranking, an expert in the field of sewer system management arranges the main causes affecting the trouble-free operation of sewer tunnels in the order that they deem to be the most rational and assigns ranks to these. In this case, rank No. 1 obtains the highest measure of significance of impact, while rank No. N has the lowest. Consequently, the ordinal scale obtained as a result of ranking is to meet the condition where the number of ranks “8” is equal to the number of ranked causes of failures “n” [26]. Further, a summary table of ranks was compiled for all experts of the group (table 2).

Table 2 – Findings of the survey of experts included in the group

Failure cause	Expert							Sum
	1	2	3	4	5	6	7	
C1	2	3	1	3	1	2	3	15
C2	6	5	5	5	4	5	5	35
C3	7	8	6	6	7	8	7	49
C4	5	6	8	7	6	6	6	44
C5	1	2	2	1	2	3	4	15
C6	4	4	3	2	3	4	2	22
C7	8	7	7	8	8	7	8	53
C8	3	1	4	4	5	1	1	19
Sum	36	36	36	36	36	36	36	–

To determine the consistency of experts, the coefficient of concordance W [26] is used. According to the findings of the survey of the experts in the field of sewer network operation and calculations of their consistency, the coefficient of concordance equal to 0.88 was obtained, which indicates a high degree of consistency of opinions in the selected group of experts.

According to the data based on the expert evaluation findings, it should be noted that among the above 8 causes of failures in smooth operation of sewer tunnels, the highest impact on the efficiency of the sewer cleaning method is exerted by causes C7, C3, C4 (the summed rank of these phenomena is minimal), specifically: deterioration of the arched section at the junctions to inspection shafts, stilling pools, shafts; deterioration of the arched section of the sewer tunnel structure; technical condition of inspection shafts, stilling pools, chambers.

Operating experience confirms the fact that about 80% of all collapses of sewer tunnels occur in the area of inspection shafts and stilling pools, where the concentration of sulfuric acid is exceeded by ten folds due to segregation of wastewater streams. It follows from the above that the issue of developing technological solutions for the protection of sewer tunnels in the immediate vicinity of inspection shafts and stilling pools is relevant.

Development of a rehabilitation method for sewer tunnels at the junctions to inspection shafts.

To deal with the problem of improving the operating reliability of the sewer tunnel section located in the area of an inspection shaft or a stilling pool, the following technological solutions have been developed to protect them against biogenic corrosion (figure 2).

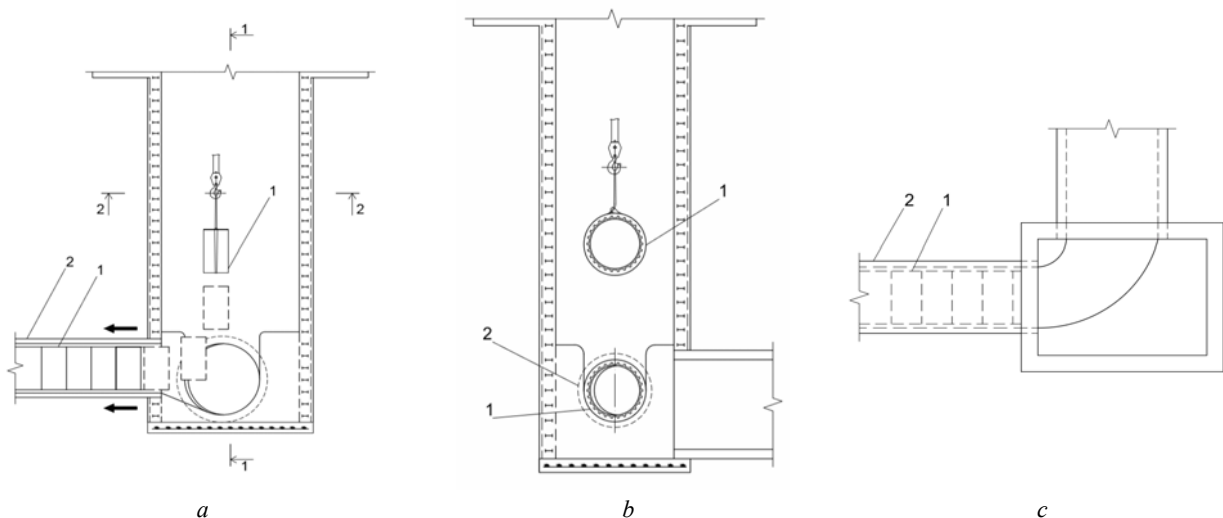

Figure 2 – Rehabilitation of the sewer tunnel at the junctions to inspection shafts:
 a – erection process diagram for reinforced concrete rings; b – section 1-1; c – section 2-2;
 1 – reinforced concrete ring with corrosion-resistant coating ; 2 – sewer tunnel to be rehabilitated

According to the results of teleinspection, the selected section of a sewer tunnel is additionally examined for the nature and degree of susceptibility to biogenic corrosion, with the determination of the exact length to be rehabilitated. After shutting down the movement of wastewater, the elements of the tunnel reinforcement lining, made of reinforced concrete ring elements with corrosion-resistant coating are put by means of winches down into the inspection shaft, previously prepared for rehabilitation work. Next, the elements of the lining are secured in the design position and by the method of buildup are pressed into the tunnel body. Jacks are used for pressing in the lining elements. The connection of the rings to each other occurs by means of couplings or sockets. After completing rehabilitation work, the equipment is dismantled from the shaft, test operations are carried out and the wastewater is started up.

Findings of research on the rehabilitation method for sewer tunnels at the junctions to inspection shafts. Preliminary, the thickness of the reinforcement lining is assigned in view of the design requirements and updated according to the results of the calculation by the finite element method performed with regard to the proposed technology of the sewer rehabilitation process. As an example, consider the rehabilitation of a sewer tunnel with a design diameter of 1840 mm, where the following initial conditions are taken for the calculation:

1. The bearing capacity of the existing reinforced concrete lining is assumed to be secured for the period of arrangement of the reinforcement structure, with the presence of localized damaged sections with unsecured strength;
2. The following loading conditions are taken as the design cases for the prefabricated lining of the reinforcement:
 - a) External hydrostatic pressure of the concrete mix during the concrete pouring the annular space;
 - b) External hydrostatic pressure of water filtered in the ground and penetrating through the reinforced concrete lining structure;
 - c) External local asymmetric pressure on the arch section (the case of an emergency condition of the sewer lining to be reinforced).

The design model for lining the reinforcement of the tunnel is a fragment of a cylindrical shell with a design diameter of 1.44 m and a length of 1.0 m, consisting of flat quadrangular finite elements of the shell measuring 0.1 x 0.1 m. The parameters of the material of the finite elements of the design model are as follows: thickness – 180 mm; modulus of elasticity $E = 1.4 \cdot 10^4$ MPa; Poisson's ratio $\nu=0.3$; ultimate tensile strength – 170 MPa [3].

The boundary conditions are taken in the form of connections in individual units in the longitudinal direction (along the axis of the sewer tunnel), and the coefficients of the elastic foundations for the plates, corresponding to the conditions of the interaction between the reinforcement structure and the nominal linearly elastic medium.

The results of the numerical simulation of the stress-strain state of the reinforcement structure are given in figure 3.

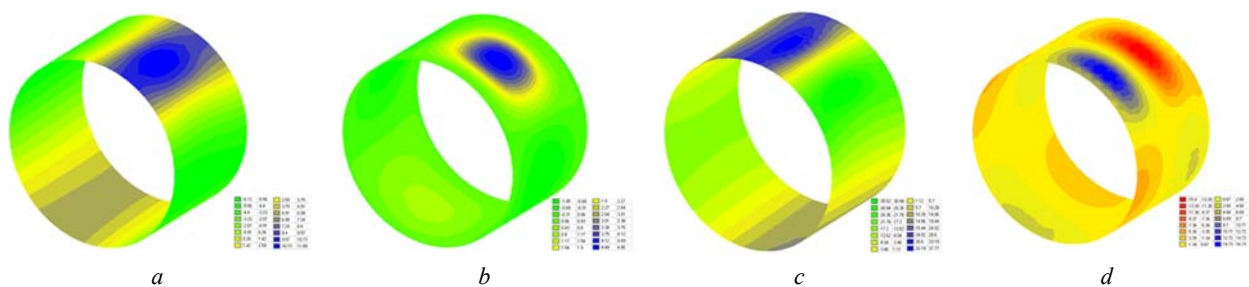

Figure 3 – Bending moments in the prefabricated lining structure of the sewer tunnel reinforcement, kN·m: *a* – in MX direction; *b* – in MY direction; *c* – in QX direction; *d* – in QY direction

To evaluate the expediency of using the proposed technology, three options have been considered: lining the tunnel reinforcement using reinforced concrete rings with corrosion-resistant coating, lining using SPIRO polyethylene pipes, and lining using fiberglass pipes. The comparison of the indicators in terms of the cost of material is shown in table 3.

Table 3 – Cost of technological solutions for rehabilitating a Ø1840 mm tunnel

Item No. of the rehabilitation method	Description of material	Nominal diameter [DN]	Unit of measurement	Cost per unit* [UAH]
1	Spiro polyethylene pipe	1600	rm	29300.00
2	Fiberglass pipe	1600	rm	28400.00
3	Reinforced concrete rings with corrosion-resistant coating	1440	rm	9800.00
*prices are stated per 1 running meter as of November 2018				

In conclusion, it should be noted that the application of the method proposed by the authors from the standpoint of saving material in comparison with analogues is almost three times more cost-effective than the use of polyethylene or fiberglass pipes.

Conclusions. In the course of the performed research the following results were obtained.

1. A review was performed of the causes of failures in smooth operation of sewer tunnels;
2. Using the expert evaluation method, it was found that most failures of reinforced concrete sewer tunnels followed by their collapses occur in the areas of their junction to the inspection shafts and stilling pools.
3. As a result of the research performed, an economically and technically efficient technology was developed for rehabilitating sewer tunnels at their junctions to inspection shafts (using lining for reinforcement made of reinforced concrete elements with corrosion-resistant coating).
4. When comparing rehabilitation options involving various materials, it is noted that the proposed rehabilitation method is more economically viable than those using polyethylene or fiberglass lining elements.

Д. Ф. Гончаренко, А. И. Алейникова, А. В. Убийвовк

Харьков ұлттық құрылыс және сәулет университеті, Харьков, Украина

ҚАЛДЫҚТАРМЕН ЖҰМЫС ІСТЕЙТІН КЕН ОРЫНДАРЫНА ҚОСЫЛУ АЛАҒЫНДА КЕПТІРУ ТУННЕЛЬДЕРІН ҚАЙТА ҚҰРУ ӘДІСІН ДАМЫТУ

Аннотация. Ағынды суларды жеткіліксіз қаржыландыру және сарқынды суларды тарату жүйесінің жоғары амортизация жағдайында жұмыс істейтін кәсіпорындар өздерінің техникалық және экономикалық мүмкіндіктері шегінде жұмыс істейді. Кәріз туннельдерін пайдаланудың қиындығы бірқатар факторларға байланысты олардың қалпына келмеуінде. Олардың негізгілері: құрылымдардың жоғары тозуы; құбырдың маңызды тереңдігі; ағымдағы жөндеу жұмыстарын жүргізуге арналған телнұсқалардың болмауы; бақылау біліктері арасындағы қашықтық 1 км дейін жетуі мүмкін; кәріз туннеліндегі агрессивті газ заттарының жоғары концентрациясына байланысты операторлар үшін өлім қаупі. Демек, зерттеудің перспективалық бағыты экономикалық тұрғыдан қалпына келтірудің баламалы технологияларын жасау арқылы олардың ұзақ өмір сүруін арттыру болып табылады, бұл шектеулі қаржыландыру жағдайында олардың тұрақты жұмысын қамтамасыз етеді. Мақалада канализация туннельдерінің пайдалану сенімділігі туралы әдебиеттерге шолу жасалады. Кәріз туннельдерінің істен шығу себептерін зерттеу нәтижелері келтірілген. Ақаулықтың келесі себептері анықталды: агрессивті экологиялық факторлардың әсерінен туннель науасының тозуы; сарқынды сулардың агрессивтілігін жүйелі түрде арттыру; кәріз туннелін салудың аркалы бөлігінің тозуы; қарау біліктерінің, сөндіру камераларының, шахталардың техникалық жағдайы; сарқынды су көлеміндегі айырмашылықтар; туннель өткелінің жанында қарқынды даму; қарау біліктері, ажыратқыш камералары, біліктері бар түйіспелердегі қойма киімі; бойлық профильге сәйкес науаның белгілеріндегі айырмашылықтар. Сараптамалық бағалау әдісін қолдана отырып, төтенше жағдайлардың басты себебі туннельдердің бақылаушы біліктермен түйісетін жерлеріндегі зақымдалғандығы болып табылады. Кәріздік туннельдерді коррозияға қарсы жабыны бар темірбетон сақиналарын қолдана отырып, қарау біліктеріне қосылатын жерлерде қалпына келтірудің жаңа әдісі жасалды. Бұл агрессивті ағынды суларға төзімді, қайта өңделген полимерлі материалдан жасалған туннель төсемінің элементтерін кезең-кезеңмен батыруға негізделген. Алдын ала, туннельді арматуралаудың қалыңдығы жобалық талаптарды ескере отырып анықталады және қалпына келтіру процесінің ұсынылған технологиясын ескере отырып орындалған соңғы элементтерді есептеу нәтижелері бойынша анықталады. Туннельді нығайту құрылымының кернеулі-деформациялық күйін

сандық модельдеу жүргізілді. Туннельді арматуралық төсемнің жобалық схемасы цилиндрлік қабықтың фрагменті болып табылады. Шекаралық шарттар бойлық бағытта (канализация туннелінің осі бойымен) жеке түйіндердегі байланыс түрінде қабылданады, сонымен қатар арматура құрылымы мен кәдімгі сызықты-серпімді орта арасындағы өзара әрекеттесу жағдайларына сәйкес келетін тақтайшаларға арналған серпімді негіз коэффициенттері қабылданады. Бақылау біліктеріне жақын жерлерде канализациялық туннельдерді қалпына келтіру үшін ұсынылған әдісті қолдану орындылығы ұсынылған және негізделген. Осы әдісті қолдану арқасында қарастырылған басқа нұсқалармен салыстырғанда қаржы ресурстарының құнын үнемдеуге қол жеткізілді.

Түйін сөздер: кәріз туннелі, тозуы, тексеру білігі, коррозия, қалпына келтіру әдісі

Д. Ф. Гончаренко, А. И. Алейникова, А. В. Убийвовк

Харьковский национальный университет строительства и архитектуры, Харьков, Украина

РАЗРАБОТКА МЕТОДА ВОССТАНОВЛЕНИЯ КАНАЛИЗАЦИОННЫХ ТОННЕЛЕЙ В МЕСТАХ ПРИМЫКАНИЯ К СМОТРОВЫМ ШАХТАМ

Аннотация. В условиях недостаточного финансирования отрасли канализационного хозяйства и высокого амортизационного износа распределительной системы водоотведения эксплуатирующие предприятия осуществляют свою деятельность на пределе своих технических и экономических возможностей. Сложность эксплуатации канализационных тоннелей заключается в их неремонтопригодности ввиду ряда факторов. Основными из них являются: высокая степень технического износа конструкций; значительная глубина заложения трубопроводов; отсутствие дублирующих распределительных линий для осуществления текущего ремонта; расстояние между смотровыми шахтами может достигать до 1 км; смертельная опасность для эксплуатирующих специалистов из-за высокой концентрации веществ агрессивной газовой среды канализационного тоннеля. Следовательно, перспективным направлением исследований является повышение их долговечности путем разработки альтернативных технологий ремонта с экономической точки зрения, что позволит обеспечить их устойчивое функционирование в условиях ограниченного финансирования. В работе выполнен обзор литературных источников относительно повышения эксплуатационной надежности канализационных тоннелей. Представлены результаты исследования причин отказа функционирования канализационных тоннелей. Установлены следующие причины отказа: износ лотка тоннеля под действием агрессивных факторов среды эксплуатации; систематическое увеличение агрессивности сточных вод; износ сводовой части конструкции канализационного тоннеля; техническое состояние смотровых шахт, камер гашения, шахтам; перепады в объемах сточных вод; интенсивная выработка вблизи трассы прохождения тоннеля; износ свода в местах примыкания к смотровым шахтам, камерам гашения, шахтам; перепады отметок лотка согласно продольного профиля. С использованием метода экспертных оценок установлено, что основной причиной возникновения аварийных ситуаций является повреждение сводовой части тоннелей в местах их примыкания к смотровым шахтам. Разработан новый метод восстановления канализационных тоннелей в местах их примыкания к смотровым шахтам с использованием железобетонных колец с антикоррозийным покрытием. Он основывается на поэтапном погружении элементов отделки тоннеля, выполненного из вторичного полимерного материала стойкого к агрессивной канализационной среде. Предварительно толщина отделки усиления тоннеля назначается с учетом конструктивных требований и уточняется по результатам расчета методом конечных элементов, выполненного с учетом предполагаемой технологии процесса восстановления. Проведено численное моделирование напряженно-деформированного состояния конструкции усиления туннеля. Расчетная схема отделки усиления тоннеля представляет собой фрагмент цилиндрической оболочки. Граничные условия приняты в виде связей в отдельных узлах в продольном направлении (вдоль оси канализационного тоннеля), а также коэффициентов упругого основания для пластин, соответствующих условиям взаимодействия конструкции усиления с условной линейно-упругой средой. Представлены и обоснованы целесообразность использования предложенного метода восстановления канализационных тоннелей в местах их примыкания к смотровым шахтам. Благодаря использованию такого метода достигается экономия затрат финансовых ресурсов, в сравнении с другими рассмотренными вариантами.

Ключевые слова: канализационный тоннель, износ, смотровая шахта, коррозия, метод восстановления.

Information about author:

Goncharenko Dmitriy, Doctor of Technical Sciences, Professor, Department of building technology, Kharkiv National University of Construction and Architecture, Kharkiv, Ukraine; gonch@kstuca.kharkov.ua; <http://orcid.org/0000-0003-1278-0895>

Aleinikova Alevtyna, PhD, Assistant, Department of building technology, Kharkiv National University of Construction and Architecture, Kharkiv, Ukraine; alevtynaal222@gmail.com; <http://orcid.org/0000-0002-2486-4263>

Ubiivovk Artem, V PhD, Associate Professor, Department of Geotechnics and Underground Constructions, Kharkiv National University of Construction and Architecture, Kharkiv, Ukraine; guartv@gmail.com; <http://orcid.org/0000-0001-5319-9429>

REFERENCES

- [1] Korinko Y.V. (2012) Development Program of the Utility Enterprise Kharkivvodokanal until 2026 [Programma razvitiya KP Kharkovvodokanal do 2026 goda]. HVK, Ukraine (in Russ.).
- [2] Aleynikova A.I., Volkov V.M., Goncharenko D.F., Zubko H.H., Starkova O.V. (2017) Methodological foundations of increasing the operational resource of underground engineering networks [Metodolohichni osnovy podovzheniy ekspluatatsiynoho resursu pidzemnykh inzhenernykh merezh]. Rarities of Ukraine, Kharkiv (in Ukr.).
- [3] Bondarenko D.O., Bulhakov V.V., Harmash O.O., Goncharenko D.F., Pilihran S.S. (2018) Sewer tunnels in Kharkov: QUO VADIS? [Kanalizatsiyini tuneli Kharkova: QUO VADIS?]. Rarities of Ukraine, Kharkiv (in Ukr.).
- [4] Goncharenko D., Aleinikova A., Volkov V., Zabelin S. (2016) Research into the factors which influence efficiency of the water supply networks reconstruction by the «Berstlining» technology. Eastern-European Journal of Enterprise Technologies. Vol. 6. P. 21-28.
- [5] Aleinikova A. (2015) Methods for evaluating the economic efficiency of water supply lines restoration based on the findings of teleinspection. Actual Problems of Economics. Vol. 182. P. 224-229.
- [6] Pantieliieva N., Mishchenko S., Pantieliieva K. (2019) The financial mechanism for providing investment lending to the economy of Ukraine with the participation of international financial institutions // Bulletin of national academy of sciences of the Republic of Kazakhstan. 2019. Vol. 6, N 380. P. 141-153. ISSN 2518-1467 (Online), ISSN 1991-3494 (Print). <https://doi.org/10.32014/2019.2518-1467.156>
- [7] Artemenko O. V., Honcharuk L. Yu., Kachur V. O., Lytvyn N. A. Environmental protection under the legislation of the Ukraine and the republic of Poland: a comparative analysis of the main features n. 2019. Vol. 6, N 382. P. 178-183. ISSN 2518-1467 (Online), ISSN 1991-3494 (Print). <https://doi.org/10.32014/2019.2518-1467.160>
- [8] Roscher H. (2015) Rehabilitation von Rohrleitungen Sanierung und Erneuerung von Verund Entsorgungsnetzen Weiterbildendes. Weimar, Weiterbildendes Studium Wasser und Umwelt, Germany.
- [9] Körkemeyer K. (2015) State-of-the-art sewer construction using precast elements. Qualitätssicherung und Fehlervermeidung. Vol. 2. P. 80-83.
- [10] Praetorius S., Schöber B. (2015) Bentonithandbuch. Ringspaltschmierung für den Rohrvortrieb Bauingenieur-Praxis. Kartoniert Ernst & Sohn, Germany.
- [11] Sterling R., Alam S., Allouche E., Condit W., Matthews J., Downey D. (2015) Studying the Life-cycle Performance of Gravity Sewer Rehabilitation Liners in North America. Procedia Engineering. Vol.165. P. 251-258.
- [12] Jeyapalan J.K., Gipson B., Biesalski M. (2015) An Evaluation of Trenchless Point Repair Solutions for Pipes of Varying Inner Diameter and Offset Joints, Pipelines, USA.
- [13] Porjadin V.I. (2014) Ecosystem groundwater resources of Kazakhstan: assessment methodology. [Jekosistemnye resursy podzemnykh vod Kazahstana: metodologiya ocenki]. News of the National Academy of Sciences of the Republic of Kazakhstan. Series of Geology and Technical Sciences. N 5. P. 47-57.
- [14] Wilson D., Filion Y., Moore I. (2017) State-of-the-art review of water pipe failure prediction models and applicability to large-diameter mains. Urban Water Journal. Vol. 14. P. 173-184.
- [15] Bakry I., Alzraiee H., Kaddoura K., Masry M. El., Zayed T. (2017) Condition Prediction for Chemical Grouting Rehabilitation of Sewer Networks. Journal of Performance of Constructed Facilities. Vol. 30. P. 362-375.
- [16] Kaushal V., Young V. (2017) Microbiologically Induced Concrete Corrosion in Sanitary Sewer Systems, Trenchless Technology and Pipe Conference TX, USA.
- [17] Almahakeri M., Moore I., Fam A. (2017) Numerical study of longitudinal bending in buried GFRP pipes subjected to lateral earth movements. Journal of Pipeline Systems Engineering and Practice. Vol. 8, P. 1.
- [18] Information on <http://https://rothenberger.com/de-de/>.
- [19] Information on <http://intelpipe.by/technologies/pipeline-flushing/method>.
- [20] Böhm A. (1993) Betrieb, Instandhaltung und Erneuerung des Wasserrohrnetzes, Vulkan-Verlag.
- [21] Nezat M. (2003) An Innovative Method for Cleaning Large Bore Sewer. New Pipeline Technologies, Security, and Safety, American Society of Civil Engineers.
- [22] Information on <http://jfas.info/index.php/jfas/article/view/148>.
- [23] Bulgakov Y. (2015) Studies of the destruction of structures of a sewer tunnel collector [Issledovaniye protsessa razrusheniya konstruktivnykh kanalizatsionnogo tonnel'nogo kollektora]. Bulletin of construction. Vol. 79. P. 79-84 (In Russ.).
- [24] Goncharenko D.F., Karzhinerova T.I., Zabelin S.A., Kurovskiy I.I. (2010) Preparation for the repair of sewer collectors [Podgotovka k remontu kanalizatsionnykh kollektorov]. Bulletin of construction. Vol. 55. P. 284-290 (in Russ.).
- [25] Zabelin S.A., Aleynikova A.I., Anishchenko A.I. (2018) Application for a patent of Ukraine for the invention of a bucket for cleaning sewer collectors № a 2018 05537 [Zayavka na polucheniye patenta Ukrainy na izobreteniyе № a 2018 05537 «Kovsh dlya ochistki kanalizatsionnykh kollektorov»] (in Ukr.).
- [26] Information on <http://https://habr.com/post/189626/>

**Publication Ethics and Publication Malpractice
in the journals of the National Academy of Sciences of the Republic of Kazakhstan**

For information on Ethics in publishing and Ethical guidelines for journal publication see <http://www.elsevier.com/publishingethics> and <http://www.elsevier.com/journal-authors/ethics>.

Submission of an article to the National Academy of Sciences of the Republic of Kazakhstan implies that the described work has not been published previously (except in the form of an abstract or as part of a published lecture or academic thesis or as an electronic preprint, see <http://www.elsevier.com/postingpolicy>), that it is not under consideration for publication elsewhere, that its publication is approved by all authors and tacitly or explicitly by the responsible authorities where the work was carried out, and that, if accepted, it will not be published elsewhere in the same form, in English or in any other language, including electronically without the written consent of the copyright-holder. In particular, translations into English of papers already published in another language are not accepted.

No other forms of scientific misconduct are allowed, such as plagiarism, falsification, fraudulent data, incorrect interpretation of other works, incorrect citations, etc. The National Academy of Sciences of the Republic of Kazakhstan follows the Code of Conduct of the Committee on Publication Ethics (COPE), and follows the COPE Flowcharts for Resolving Cases of Suspected Misconduct (http://publicationethics.org/files/u2/New_Code.pdf). To verify originality, your article may be checked by the Cross Check originality detection service <http://www.elsevier.com/editors/plagdetect>.

The authors are obliged to participate in peer review process and be ready to provide corrections, clarifications, retractions and apologies when needed. All authors of a paper should have significantly contributed to the research.

The reviewers should provide objective judgments and should point out relevant published works which are not yet cited. Reviewed articles should be treated confidentially. The reviewers will be chosen in such a way that there is no conflict of interests with respect to the research, the authors and/or the research funders.

The editors have complete responsibility and authority to reject or accept a paper, and they will only accept a paper when reasonably certain. They will preserve anonymity of reviewers and promote publication of corrections, clarifications, retractions and apologies when needed. The acceptance of a paper automatically implies the copyright transfer to the National Academy of Sciences of the Republic of Kazakhstan.

The Editorial Board of the National Academy of Sciences of the Republic of Kazakhstan will monitor and safeguard publishing ethics.

Правила оформления статьи для публикации в журнале смотреть на сайте:

[www:nauka-nanrk.kz](http://www.nauka-nanrk.kz)

ISSN 2518-170X (Online), ISSN 2224-5278 (Print)

<http://www.geolog-technical.kz/index.php/en/>

Редакторы *Д. С. Аленов, М. С. Ахметова, Т. А. Апендиев*
Верстка *Д. А. Абрахимовой*

Подписано в печать 13.04.2020.
Формат 70x881/8. Бумага офсетная. Печать – ризограф.
13 п.л. Тираж 300. Заказ 2.