

ISSN 2518-170X (Online),
ISSN 2224-5278 (Print)

ҚАЗАҚСТАН РЕСПУБЛИКАСЫ
ҰЛТТЫҚ ҒЫЛЫМ АКАДЕМИЯСЫНЫҢ
Қ. И. Сәтпаев атындағы Қазақ ұлттық техникалық зерттеу университеті

Х А Б А Р Л А Р Ы

ИЗВЕСТИЯ

НАЦИОНАЛЬНОЙ АКАДЕМИИ НАУК
РЕСПУБЛИКИ КАЗАХСТАН
Казакский национальный исследовательский
технический университет им. К. И. Сатпаева

NEWS

OF THE ACADEMY OF SCIENCES
OF THE REPUBLIC OF KAZAKHSTAN
Kazakh national research technical university
named after K. I. Satpayev

**SERIES
OF GEOLOGY AND TECHNICAL SCIENCES**

6 (438)

NOVEMBER – DECEMBER 2019

THE JOURNAL WAS FOUNDED IN 1940

PUBLISHED 6 TIMES A YEAR

ALMATY, NAS RK

NAS RK is pleased to announce that News of NAS RK. Series of geology and technical sciences scientific journal has been accepted for indexing in the Emerging Sources Citation Index, a new edition of Web of Science. Content in this index is under consideration by Clarivate Analytics to be accepted in the Science Citation Index Expanded, the Social Sciences Citation Index, and the Arts & Humanities Citation Index. The quality and depth of content Web of Science offers to researchers, authors, publishers, and institutions sets it apart from other research databases. The inclusion of News of NAS RK. Series of geology and technical sciences in the Emerging Sources Citation Index demonstrates our dedication to providing the most relevant and influential content of geology and engineering sciences to our community.

Қазақстан Республикасы Ұлттық ғылым академиясы "ҚР ҰҒА Хабарлары. Геология және техникалық ғылымдар сериясы" ғылыми журналының Web of Science-тің жаңаланған нұсқасы Emerging Sources Citation Index-те индекстелуге қабылданғанын хабарлайды. Бұл индекстелу барысында Clarivate Analytics компаниясы журналды одан әрі the Science Citation Index Expanded, the Social Sciences Citation Index және the Arts & Humanities Citation Index-ке қабылдау мәселесін қарастыруда. Web of Science зерттеушілер, авторлар, баспашылар мен мекемелерге контент тереңдігі мен сапасын ұсынады. ҚР ҰҒА Хабарлары. Геология және техникалық ғылымдар сериясы Emerging Sources Citation Index-ке енуі біздің қоғамдастық үшін ең өзекті және беделді геология және техникалық ғылымдар бойынша контентке адалдығымызды білдіреді.

НАН РК сообщает, что научный журнал «Известия НАН РК. Серия геологии и технических наук» был принят для индексирования в Emerging Sources Citation Index, обновленной версии Web of Science. Содержание в этом индексировании находится в стадии рассмотрения компанией Clarivate Analytics для дальнейшего принятия журнала в the Science Citation Index Expanded, the Social Sciences Citation Index и the Arts & Humanities Citation Index. Web of Science предлагает качество и глубину контента для исследователей, авторов, издателей и учреждений. Включение Известия НАН РК. Серия геологии и технических наук в Emerging Sources Citation Index демонстрирует нашу приверженность к наиболее актуальному и влиятельному контенту по геологии и техническим наукам для нашего сообщества.

Б а с р е д а к т о р ы
э. ғ. д., профессор, ҚР ҰҒА академигі

И.К. Бейсембетов

Бас редакторының орынбасары

Жолтаев Г.Ж. проф., геол.-мин. ғ. докторы

Р е д а к ц и я а л қ а с ы:

Абаканов Т.Д. проф. (Қазақстан)
Абишева З.С. проф., академик (Қазақстан)
Агабеков В.Е. академик (Беларусь)
Алиев Т. проф., академик (Әзірбайжан)
Бакиров А.Б. проф., (Қырғыстан)
Беспәев Х.А. проф. (Қазақстан)
Бишимбаев В.К. проф., академик (Қазақстан)
Буктуков Н.С. проф., академик (Қазақстан)
Булат А.Ф. проф., академик (Украина)
Ганиев И.Н. проф., академик (Тәжікстан)
Грэвис Р.М. проф. (АҚШ)
Ерғалиев Г.К. проф., академик (Қазақстан)
Жуков Н.М. проф. (Қазақстан)
Қожахметов С.М. проф., академик (Қазақстан)
Конторович А.Э. проф., академик (Ресей)
Курскеев А.К. проф., академик (Қазақстан)
Курчавов А.М. проф., (Ресей)
Медеу А.Р. проф., академик (Қазақстан)
Мұхамеджанов М.А. проф., корр.-мүшесі (Қазақстан)
Нигматова С.А. проф. (Қазақстан)
Оздоев С.М. проф., академик (Қазақстан)
Постолатий В. проф., академик (Молдова)
Ракишев Б.Р. проф., академик (Қазақстан)
Сейтов Н.С. проф., корр.-мүшесі (Қазақстан)
Сейтмуратова Э.Ю. проф., корр.-мүшесі (Қазақстан)
Степанец В.Г. проф., (Германия)
Хамфери Дж.Д. проф. (АҚШ)
Штейнер М. проф. (Германия)

«ҚР ҰҒА Хабарлары. Геология мен техникалық ғылымдар сериясы».

ISSN 2518-170X (Online),

ISSN 2224-5278 (Print)

Меншіктенуші: «Қазақстан Республикасының Ұлттық ғылым академиясы» РҚБ (Алматы қ.).

Қазақстан республикасының Мәдениет пен ақпарат министрлігінің Ақпарат және мұрағат комитетінде 30.04.2010 ж. берілген №10892-Ж мерзімдік басылым тіркеуіне қойылу туралы куәлік.

Мерзімділігі: жылына 6 рет.

Тиражы: 300 дана.

Редакцияның мекенжайы: 050010, Алматы қ., Шевченко көш., 28, 219 бөл., 220, тел.: 272-13-19, 272-13-18,
<http://www.geolog-technical.kz/index.php/en/>

© Қазақстан Республикасының Ұлттық ғылым академиясы, 2019

Редакцияның Қазақстан, 050010, Алматы қ., Қабанбай батыра көш., 69а.

мекенжайы: Қ. И. Сәтбаев атындағы геология ғылымдар институты, 334 бөлме. Тел.: 291-59-38.

Типографияның мекенжайы: «Аруна» ЖК, Алматы қ., Муратбаева көш., 75.

Г л а в н ы й р е д а к т о р
д. э. н., профессор, академик НАН РК

И. К. Бейсембетов

Заместитель главного редактора

Жолтаев Г.Ж. проф., доктор геол.-мин. наук

Р е д а к ц и о н н а я к о л л е г и я:

Абаканов Т.Д. проф. (Казахстан)
Абишева З.С. проф., академик (Казахстан)
Агабеков В.Е. академик (Беларусь)
Алиев Т. проф., академик (Азербайджан)
Бакиров А.Б. проф., (Кыргызстан)
Беспаяев Х.А. проф. (Казахстан)
Бишимбаев В.К. проф., академик (Казахстан)
Буктуков Н.С. проф., академик (Казахстан)
Булат А.Ф. проф., академик (Украина)
Ганиев И.Н. проф., академик (Таджикистан)
Грэвис Р.М. проф. (США)
Ергалиев Г.К. проф., академик (Казахстан)
Жуков Н.М. проф. (Казахстан)
Кожаметов С.М. проф., академик (Казахстан)
Конторович А.Э. проф., академик (Россия)
Курскеев А.К. проф., академик (Казахстан)
Курчавов А.М. проф., (Россия)
Медеу А.Р. проф., академик (Казахстан)
Мухамеджанов М.А. проф., чл.-корр. (Казахстан)
Нигматова С.А. проф. (Казахстан)
Оздоев С.М. проф., академик (Казахстан)
Постолатий В. проф., академик (Молдова)
Ракишев Б.Р. проф., академик (Казахстан)
Сейтов Н.С. проф., чл.-корр. (Казахстан)
Сейтмуратова Э.Ю. проф., чл.-корр. (Казахстан)
Степанец В.Г. проф., (Германия)
Хамфери Дж.Д. проф. (США)
Штейнер М. проф. (Германия)

«Известия НАН РК. Серия геологии и технических наук».

ISSN 2518-170X (Online),

ISSN 2224-5278 (Print)

Собственник: Республиканское общественное объединение «Национальная академия наук Республики Казахстан (г. Алматы)

Свидетельство о постановке на учет периодического печатного издания в Комитете информации и архивов Министерства культуры и информации Республики Казахстан №10892-Ж, выданное 30.04.2010 г.

Периодичность: 6 раз в год

Тираж: 300 экземпляров

Адрес редакции: 050010, г. Алматы, ул. Шевченко, 28, ком. 219, 220, тел.: 272-13-19, 272-13-18,
<http://nauka-nanrk.kz/geology-technical.kz>

© Национальная академия наук Республики Казахстан, 2019

Адрес редакции: Казахстан, 050010, г. Алматы, ул. Кабанбай батыра, 69а.

Институт геологических наук им. К. И. Сатпаева, комната 334. Тел.: 291-59-38.

Адрес типографии: ИП «Аруна», г. Алматы, ул. Муратбаева, 75

E d i t o r i n c h i e f

doctor of Economics, professor, academician of NAS RK

I. K. Beisembetov

Deputy editor in chief

Zholtayev G.Zh. prof., dr. geol-min. sc.

E d i t o r i a l b o a r d:

Abakanov T.D. prof. (Kazakhstan)
Abisheva Z.S. prof., academician (Kazakhstan)
Agabekov V.Ye. academician (Belarus)
Aliyev T. prof., academician (Azerbaijan)
Bakirov A.B. prof., (Kyrgyzstan)
Bespayev Kh.A. prof. (Kazakhstan)
Bishimbayev V.K. prof., academician (Kazakhstan)
Buktukov N.S. prof., academician (Kazakhstan)
Bulat A.F. prof., academician (Ukraine)
Ganiyev I.N. prof., academician (Tadjikistan)
Gravis R.M. prof. (USA)
Yergaliev G.K. prof., academician (Kazakhstan)
Zhukov N.M. prof. (Kazakhstan)
Kozhakhmetov S.M. prof., academician (Kazakhstan)
Kontorovich A.Ye. prof., academician (Russia)
Kurskeyev A.K. prof., academician (Kazakhstan)
Kurchavov A.M. prof., (Russia)
Medeu A.R. prof., academician (Kazakhstan)
Muhamedzhanov M.A. prof., corr. member. (Kazakhstan)
Nigmatova S.A. prof. (Kazakhstan)
Ozdoev S.M. prof., academician (Kazakhstan)
Postolatii V. prof., academician (Moldova)
Rakishev B.R. prof., academician (Kazakhstan)
Seitov N.S. prof., corr. member. (Kazakhstan)
Seitmuratova Ye.U. prof., corr. member. (Kazakhstan)
Stepanets V.G. prof., (Germany)
Humphery G.D. prof. (USA)
Steiner M. prof. (Germany)

News of the National Academy of Sciences of the Republic of Kazakhstan. Series of geology and technology sciences.

ISSN 2518-170X (Online),

ISSN 2224-5278 (Print)

Owner: RPA "National Academy of Sciences of the Republic of Kazakhstan" (Almaty)

The certificate of registration of a periodic printed publication in the Committee of information and archives of the Ministry of culture and information of the Republic of Kazakhstan N 10892-Ж, issued 30.04.2010

Periodicity: 6 times a year

Circulation: 300 copies

Editorial address: 28, Shevchenko str., of. 219, 220, Almaty, 050010, tel. 272-13-19, 272-13-18,
<http://nauka-nanrk.kz/geology-technical.kz>

© National Academy of Sciences of the Republic of Kazakhstan, 2019

Editorial address: Institute of Geological Sciences named after K.I. Satpayev
69a, Kabanbai batyr str., of. 334, Almaty, 050010, Kazakhstan, tel.: 291-59-38.

Address of printing house: ST "Aruna", 75, Muratbayev str, Almaty

NEWS

OF THE NATIONAL ACADEMY OF SCIENCES OF THE REPUBLIC OF KAZAKHSTAN

SERIES OF GEOLOGY AND TECHNICAL SCIENCES

ISSN 2224-5278

Volume 6, Number 438 (2019), 184 – 189

<https://doi.org/10.32014/2019.2518-170X.169>

UDC 626. 823.4:502.7

**S. K. Joldassov¹, G. A. Sarbassova¹, M. M. Bekmuratov¹,
B. Sch. Smailov¹, E. I. Rustem¹, N. Zh. Zholamanov¹, A. A. Yangiev²**

¹M. Kh. Dulaty Taraz State University, Department of Water resources, Kazakhstan,

²Tashkent Institutes of Engineers of Irrigation and Agricultural Mechanization,

Department of Hydrotechnical structures and engineering structures, Uzbekistan.

E-mail: arnur_68@mail.ru, gulimjan@mail.ru, bekmuratov_63@mail.ru,

1115878@mail.ru, rustem_ergali@mail.ru, nurassa@mail.ru, yangiev_asror_63@mail.ru

NEW CONSTRUCTIONS OF SEDIMENT EXCLUSION WORKS

Abstract. Presents regulating ways of transporting ability and new constructions of sediment exclusion works. For comparison, it has been considered the works of leading experts in this field of science. Methodological and theoretical basis of the study were scientific works of native and CIS scientists on the problems of improving the construction and researches in sediment exclusion works. To achieve the objectives, there were used general scientific methods to study the improvement of construction and transportation ability of sediment exclusion works with longitudinal slotted holes. The results given of experimental research of construction of sediment exclusion works with longitudinal slotted holes. Theory, methods, results of research and new construction of sediment exclusion works, which derived from the results of field research in Tasmuryn, the main channel of the river of Ily Almaty region. Taking into account the experimental research of construction considered, given recommendations to make an experimental research of sand trap structures with longitudinal sediment exclusion slots. Research results application area. Key findings and practical recommendations can be used as a methodological basis for the further deepening research of sand traps with longitudinal sediment exclusion slots.

Keywords: construction of sand traps, sediment exclusion works, longitudinal slotted holes, bottom sediments, transportation ability, helical motion, slurry pipeline.

Introduction. A wide-spread, sufficiently effective sediment exclusion (works) structure is considered to be a bottom transverse slurry pipeline of cylindrical type, to which sediments are supplied by parallel tubes, located along the stream at certain distances. Pairing of the tube to a slurry pipeline performed tangentially to the upper part so that biphasic bottom stream moves in the slurry pipeline helically. Sustainable economic development of Kazakhstan and the socio-ecological situation of the population of the country depend on the conditions of water supply and ecological well-being throughout the country. Ensuring the water security of the state has always been at the center of attention of the Government, and first of all, the Head of State is giving this vital problem President of Kazakhstan N.A. Nazarbayev [1, 2].

According to A.I. Arykova [1], helical motion of the flow occurs as a result of translational motion and transverse circulation connection, formed by the water entering through the lateral openings, represented either in the form of a longitudinal slit or separate apertures located at certain distances from each other.

Due to this water flow nature, the intensity of the flow rotation along the length varies and mostly depends on the input speed of the water flow into openings. Due to the variability of the water divergence along the length of the slurry pipeline, its movement is uneven. All this complicates the kinematic picture of the flow motion and therefore the conditions which determine the movement of uniformly-screw flow, as well as longitudinal-screw flow, which are not suitable for our problem. It should also be noted that the results for screw-flow models are based on the Euler's differential equations, without taking into account terms representing the resistance forces, which may not display the actual picture of the real flow movement.

If, in addition, we take into account the fact that we are confronted with the motion of a stream of increased turbulence due to the addition of the liquid with normal components to the flow axis along the length of the fluid, it is obvious that to describe the motion of the entire flow, one must take into account the energy losses due to turbulent mixing.

However, as is known, the system of differential equations for the steady motion of a viscous incompressible fluid under turbulent conditions is not closed.

Methods of the research. "The longitudinal helical motion is a special case of a vortex flow circulation, and, speaking closely, not a screw" writes O. F. Vasiliev [3] in his work. In general the movement with transverse circulation and in the case of screw motion, the current function $f(\Psi)$ is to be expressed through the longitudinal elements and the transverse velocity of the water flow which depends on the nature of the distribution of the latter over the cross section. The paper [3] presents the results of theoretical studies of an inviscid fluid in screw and circulation flows, which continues theory founded by I. S. Gromeko [4] in this field.

Much of the work [3] is devoted to the study of the general case of two-parameter inhomogeneous motion flow screw ($\lambda \neq \text{const}$) as a special case of a two-parameter vortex motion. By definition, the two-parameter flow is a flow whose components, velocity depends only on two coordinates. The two-parameter screw flow in the cylindrical coordinate system, when the motion does not depend on the coordinate φ , is given in system of equations as follows:

$$V_r r = \frac{\partial \psi}{\partial z}, \quad V_z r = -\frac{\partial \psi}{\partial r}; \quad (1)$$

$$V_\varphi r = F(\psi); \quad (2)$$

$$\frac{\partial^2 \varphi}{\partial z^2} + r \frac{\partial}{\partial r} \left(\frac{1}{r} * \frac{\partial \psi}{\partial r} \right) + F(\psi) \cdot F'(\psi) = 0, \quad (3)$$

where r is the radius; V - peripheral velocity; ψ - stream function.

Here $-F'(\psi) = \lambda$.

Following equation describes a one-parameter axisymmetric screw flow

$$\frac{V_\varphi}{r} \frac{d(V_\varphi r)}{dr} + V_z \frac{dV_z}{dr} = 0. \quad (4)$$

In this case

$$\lambda = -\frac{1}{V_\varphi} \frac{dV_z}{dr}. \quad (5)$$

Equations (4) and (5) describe motion of uniform screw of inviscid fluid flow in a straight circular tube.

The coupling of pipes to the slurry pipeline with respect to the lower part of the pipe is very relevant, but in this version the pipes are arranged with reverse bias against the stream [5].

It is known that the conveying capacity of a screw-twisted flow is several times greater than the conveying capacity of a ramjet (straight flow) [6]. The degree of twist as well as the conveying capacity of the flow can be regulated by:

- 1) axial feed of ramjet (straight flow) into slurry pipeline;
- 2) feeding additional tangential flow of the upper clarified part of the flow channel into the slurry pipeline;
- 3) establishing of cone valve at the end of slurry pipeline with the mouth of the cone inside the tube (slurry pipeline);
- 4) setting nozzle at the end of the slurry pipeline in the form of a truncated cone.

In the first case, the ramjet (straight flow) is superimposed on a swirling external flow, the movement process of which is studied in laboratory conditions [7].

Two designs of hydraulic elevators have been investigated: with direct flow and with tangential feeds of the intake medium. The performed studies of the characteristics of the hydraulic elevator at different

distances of the working nozzle from the upper mixing chamber showed that there is an optimum distance at which the efficiency of hydraulic elevator operation is highest.

In the second case, imposition of internal and external swirling flows occurs [6].

In the third case, three axial flow formed in the slurry pipeline: peripheral sediment transporting stream, air cord in the nucleus, and between them the reverse current [6].

In the fourth case, the slurry pipeline formed four streams: an air cord (axial), peripheral (trim) and near the axial air cord flows directed towards the exit of the slurry pipeline and in the middle of the radius between zones of equal axial direction - annular zone of recurrent fluid flow [6].

Results and discussion. Based on the design of the obtained prepatent [2], field studies were conducted at 63 picket of the Tasmuryn main canal in the Almaty region. 5 series of experiments were conducted where the length of the longitudinal slits varied from 0,50m to 2,66m (0.5 m, 1.0 m, 1.5 m, 2.0 m; 2,66 m). Below are the main hydraulic characteristics in the alignment of the sand trap.

Main hydraulic characteristics in the alignment of the sand trap

Picket	Date dd.mm.yyyy	Length of longitudinal slit, m	The average depth, m	The average velocity, m/s	Channel consumption, m ³ /s
63	15.08.2012	0,50	1,88	0,37	49,35
63+40		0,50	1,94	0,363	55,87
63+46		0,50	1,98	0,362	54,55
63		1,0	1,92	0,364	57,48
63+40		1,0	1,92	0,380	59,34
63+46		1,0	2,10	0,412	58,043
63		1,50	1,98	0,40	55,763
63+40		1,50	1,96	0,42	54,55
63+46		1,50	2,54	0,41	54,92
63		2,0	2,00	0,369	54,98
63+40		2,0	2,01	0,375	53,86
63,46		2,0	2,01	0,368	54,76
63		2,66	1,94	0,373	49,68
63+40		2,66	1,95	0,378	57,065
63+46		2,66	1,91	0,373	57,010

In general, a new sand trap design with longitudinal sediment transporting(ation) slots worked well. Water consumption for washing sediment was approximately 5-7% of the total flow channel. This is a good result, but still, there were some shortcomings, such as, longitudinal slots of the upstream side were quickly filled with larger deposits. And also, under slurry pipeline from the upper side sand hillocks accumulate and reduce the effectiveness of the device.

We were given the task - improving the reliability of the peskogriavelovki and hydrological transport model in the slurry pipeline. Filed application for the invention was obtained and prepatents [8]. Offered peskogriavelovka includes slurry pipeline and a device for capturing a picture sediment with longitudinal receiving slot openings arranged parallel to the channel axis for slurry pipeline, i.e. downstream and adjacent to the slurry pipeline to the downstream side.

The desired result is achieved by a device for the slurry pipeline sediment capturing a picture with longitudinal slotted holes arranged in the downstream of and adjacent to the downstream side with a slurry pipeline and a slurry pipeline installation about a vertical supply pipe in it additional expense.

Into account, the accumulation of sand hills under slurry pipeline from the upstream side, we proposed a new design sand trap [9], comprising a slurry pipeline and a device for capturing a picture sediment with longitudinal receiving slot openings arranged parallel to the channel axis for slurry pipeline, i.e. downstream and adjacent to the slurry pipeline to the downstream side, and also took into account the types of laboratory research and regulation of the conveying capacity of irrigation channels [10, 11].

The desired result is achieved by a device for gripping sediment in the form of a slurry pipeline galleries with longitudinal slotted holes arranged in the downstream of and adjacent to a slurry pipeline from the downstream side and the setting before slurry pipeline from the ground to the top of the pipe reinforced concrete slab as a slope to prevent entry of sediment various kinds under slurry pipeline pipe. Figure 1 shows the plan of the sand trap, figure 2 shows the section A-A in figure 1, figure 3 shows the section B-B in figure 1.

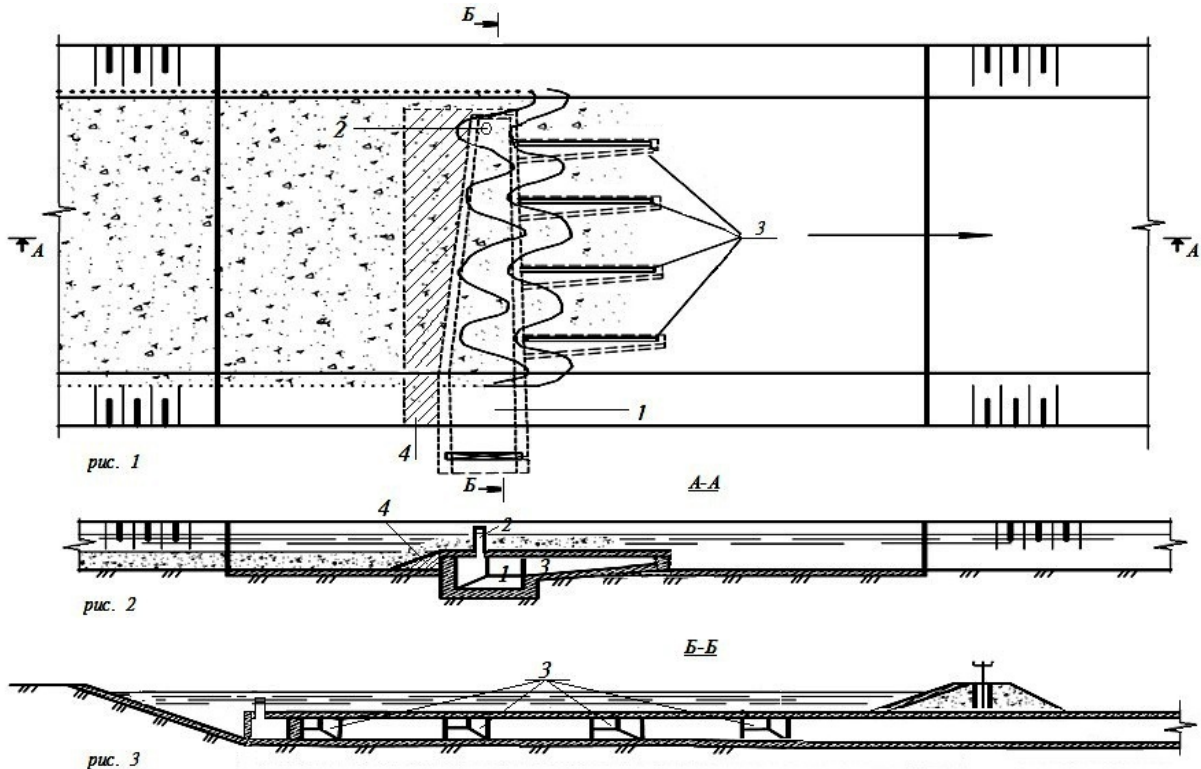

Figures 1–3 – Sand trap with longitudinal slotted holes

Sand trap with longitudinal slotted holes consists of slurry pipeline 1, a vertical tube 2 of circular or rectangular cross section, welded at the initial part of slurry pipeline tangentially thereto and tube 3 with longitudinal receiving slot openings arranged parallel to the channel axis by the downstream and adjacent to a slurry pipeline with downstream side and a reinforced concrete slab 4 placed in front slope slurry pipeline from the ground to the top of the pipe (on the axis of the tube).

The apparatus operates as follows. Apparatus of sediment exclusion works tube 3 with longitudinal slotted holes from bottom water in earthen channels allow to skip larger drifts not pulling on the longitudinal slit, and setting a slurry pipeline 1 tangential vertical pipe 2, allows due tangential Incoming additionally twists the main stream coming from sediment exclusion picture in one direction. Addition to the construction of reinforced concrete slabs 4 in the form of a slope in front of the installed slurry pipeline from the ground to the top of the pipe (on the pipe axis) and prevents ingress of bottom sediments and sediment before tractional slurry pipeline pipe, which is important in the operation of the sand trap for a long time. The initial portion and the entire length of slurry pipeline sedimentation does not occur and the whole pulp goes into relief channel and further discharged back into the river or natural depressions terrain.

For comparison and analysis of the results of the works of native and foreign scientists engaged in the problems of deposits were studied and clean sediments in earthen canals and sediment exclusion devices [12-22].

Conclusions. Estimated invention relate to the field of hydraulic engineering, in particular to the construction sediment exclusion galleries, and can be used to prevent deposition of sediment in the slurry pipeline galleries and enhance their transporting capacity. The article presents the theory, methods, and results of research and new designs of sediment exclusion works construction derived from the results of field research in Tasmuryn's main channel of the river Ily of Almaty region. The data structure of the devices it is possible, using available technology on the basis of the current level of technology and knowledge, as its design is fairly simple, but the implementation of these devices has long been well mastered the relevant enterprises of different levels.

**С. К. Джолдасов¹, Г. А. Сарбасова¹, М. М. Бекмуратов¹,
Б. Ш. Смаилов¹, Е. И. Рустем¹, Н. Ж. Жоламанов¹, А. А. Янгиев²**

¹М. Х. Дулати атындағы Тараз мемлекеттік университеті, «Су ресурстары» кафедрасы, Қазақстан,
²Ташкент суару және ауыл шаруашылығын механикаландыру инженерлер институты,
«Гидротехникалық құрылыстар және инженерлік құрылыстар» кафедрасы, Өзбекстан

ТАСЫНДЫТҮТҚЫШ ҚҰРЫЛЫМДАРДЫҢ ЖАҢА КОНСТРУКЦИЯЛАРЫ

Аннотация. Жұмыста тасындытұтқыш құрылымдардың жаңа конструкциялары мен олардың тасымалдау қабілетін реттеу жолдары келтірілген. Салыстыру үшін ғылымның осы саласындағы жетекші мамандардың еңбектері қарастырылған.

Зерттеудің әдістемелік және теориялық негізі отандық және ТМД елдері ғалымдарының, тасындытұтқыш құрылымдардың конструкцияларын жетілдіру және зерттеу сұрақтарына қатысты ғылыми еңбектері болып табылады. Зерттеу мәселелерін шешу үшін бойлық саңылаулы тесігі бар тасындытұтқыш құрылымдардың өткізу қабілеті мен конструкцияларын жетілдіруді жақсартуды болмыстық зерттеудің жалпы ғылыми әдістері қолданылды. Бойлық саңылаулы тесігі бар тасындытұтқыш құрылымдардың конструкцияларын эксперименталдық зерттеудің нәтижелері. Алматы облысы Іле өзені Тасмұрын магистрал каналындағы болмыстық зерттеулер нәтижесі негізінде алынған тасындытұтқыш құрылымдардың жаңа конструкцияларын зерттеу нәтижелері, зерттеу әдістемесі, теориясы келтірілген. Қарастырылатын конструкцияны эксперименталдық зерттеулер ескеріліп, бойлық саңылаулы құмтұтқыштардың конструкцияларын эксперименталдық зерттеулерді жүргізуге нұсқаулықтар ұсынылған. Негізгі қорытындылар мен тәжірибелік ұсыныстар бойлық саңылаулы тасындытұтқыш құмтұтқыштарды зерттеуді одан ары тереңдету үшін әдістемелік негіз ретінде пайдаланылуы мүмкін.

Түйін сөздер: құмқиыршықтастұтқыштардың конструкциялары, тасындытұтқыш құрылымдар, бойлық саңылаулы тесіктер, түпкі тасындылар, өткізу қабілеті, бұрандалы қозғалыс, құмқойыртпақ құбыры.

**С. К. Джолдасов¹, Г. А. Сарбасова¹, М. М. Бекмуратов¹,
Б. Ш. Смаилов¹, Е. И. Рустем¹, Н. Ж. Жоламанов¹, А. А. Янгиев²**

¹Таразский государственный университет им. М. Х. Дулати, кафедра «Водные ресурсы», Казахстан,
²Ташкентский институт инженеров ирригации и механизации сельского хозяйства,
кафедра «Гидротехнические сооружения и инженерные конструкции», Узбекистан

НОВЫЕ КОНСТРУКЦИИ НАНОСОПЕРЕХВАТЫВАЮЩИХ СООРУЖЕНИЙ

Аннотация. В работе приведены пути регулирования транспортирующей способности и новые конструкции наносоперехватывающих сооружений. Для сравнения рассмотрены работы ведущих специалистов в этой области науки.

Методической и теоретической основой исследования явились научные труды отечественных и ученых СНГ по проблемам совершенствования конструкций и исследований наносоперехватывающих сооружений. Для решения поставленных задач были использованы общенаучные методы исследования улучшения конструкции и пропускной способности наносоперехватывающих сооружений с продольными щелевыми отверстиями. Даны результаты экспериментальных исследований конструкций наносоперехватывающих сооружений с продольными щелевыми отверстиями; теория, методы, результаты исследования и новые конструкции наносоперехватывающих сооружений, полученных на основе результатов натурных исследований в Тасмурынском магистральном канале реки Или Алматинской области.

С учетом экспериментальных обследований рассматриваемой конструкции, предложены рекомендации проведения экспериментальных исследований конструкций песколовков с продольными наносозахватными щелями. Основные выводы и практические рекомендации могут быть использованы в качестве методической основы для дальнейшего углубления исследований песколовков с продольными наносозахватными щелями.

Ключевые слова: конструкции пескогравиеловков; наносоперехватывающие сооружения; продольные щелевые отверстия; донные наносы; пропускная способность; винтообразное движение; пульповод.

Information about authors:

Joldassov S. K., Candidate of Technical Sciences, Acting Associate, department of Water resources, M. Kh. Dulati Taraz State University, Kazakhstan; arnur_68@mail.ru; <https://orcid.org/0000-0001-8158-6290>

Sarbassova G. A., Candidate of Technical Sciences, Acting Associate, department of Water resources, M. Kh. Dulati Taraz State University, Kazakhstan; gulimjan@mail.ru; <https://orcid.org/0000-0002-1651-2583>

Bekmuratov M. M., Candidate of Technical Sciences, Associate, department of Water resources, M. Kh. Dulati Taraz State University, Kazakhstan; bekmuratov_63@mail.ru; <https://orcid.org/0000-0002-9762-6303>

Smailov B. Sch., Doctoral student specialty 6D074400 – "Hydraulic Engineering and Facilities", department of Water resources, M. Kh. Dulati Taraz State University, Kazakhstan; 1115878@mail.ru; <https://orcid.org/0000-0003-1132-6762>

Rustem E. I., Doctoral student specialty 6D074400 – "Hydraulic Engineering and Facilities", department of Water resources, M. Kh. Dulati Taraz State University, Kazakhstan; rustem_ergali@mail.ru; <https://orcid.org/0000-0002-1237-9711>

Zholamanov N. Zh., Doctoral student specialty 6D074400 – "Hydraulic Engineering and Facilities", department of Water resources, M. Kh. Dulati Taraz State University, Kazakhstan; nurassa@mail.ru; <https://orcid.org/0000-0003-1993-0606>

Yangiev A. A., doctor of technical sciences, professor, department of Hydrotechnical structures and engineering structures, Tashkent Institutes of Engineers of Irrigation and Agricultural Mechanization, Department of Hydrotechnical structures and engineering structures, Uzbekistan; yangiev_asror_63@mail.ru; <https://orcid.org/0000-0001-5979-275X>

REFERENCES

- [1] Arykova A.I. (1984) Helical movement in the flow of washing devices of waterworks. Almaty: Science. 96 p. (in Russ.).
- [2] Mukhamedzhanov M.A., Sagin J. (2018) Relation between surface water and groundwater as the factor formation of groundwater renewable resources of the territory of Kazakhstan // News of the National academy of sciences of the Republic of Kazakhstan. Series of Geology and Technical Sciences. Vol. 5, N 431 (2018). P. 15-17. <https://doi.org/10.32014/2018.2518-170X.4> ISSN 2518-170X (Online), ISSN 2224-5278 (Print) (in Eng.).
- [3] Vasiliev O.F. (1958) Fundamentals of mechanics of screw and flow patterns. M.; L. 65 p. (in Russ.).
- [4] Gromeko I.S. (1952) Some cases of the motion of an incompressible fluid. M. 295 p. (in Russ.).
- [5] Abduramanov A.A., Utegaliev T.T., Donis D.K. (1999) Some regulatory issues of superficial mode of large channels. Thermal and dynamics of rivers, reservoirs and coastal sea zones // V - Conference Proceedings. Moscow (in Russ.).
- [6] Kasabekov M.I. (1999) Experimental study of mixing coaxial swirling flow in a cylindrical tube // International scientific-practical conference "Engineering in a market economy". Taraz: TarSU (in Russ.).
- [7] Abduramanov A.A., Seytasanov I.S., Donis D.K. (1998) Resource-saving design of hydraulic elevator and the results of its research // Science and Education of South Kazakhstan. 14 p. (in Russ.).
- [8] Joldassov S.K., Abduramanov A., Sarbassova G.A., Tulepbaeva N.A. (2012) Sand and gravel trap with slots // AS RK №76993 (in Russ.).
- [9] Joldassov S.K., Maliktayuly M., Sennikov M.N., Moldamuratov Zh.N. (2015) Innovative patent RK №30563, bullet. № 12 (in Russ.).
- [10] Joldassov S.K., Esengeldieva P.N. (2012) One longitudinal (symmetrical) flow through the hole in the spread of research // Conference dedicated to N. A. Abdullayev (in Kaz.).
- [11] Sennikov M.N., Joldassov S.K., Moldamuratov Zh.N. (2015) Regulation of the conveying capacity of irrigation canals. Science, education, society: current issues and prospects // Collection of scientific works on the materials of the International scientific-practical conference. M.: AR-Consult (in Russ.).
- [12] Robinson A.R. (1960) Vortex tube sand trap. Des. Am. Soc. Civel Engineezs Proc. 86 : 4-55 (in Eng.).
- [13] Shen H.W. (1970) River mechanics. Chap tez 22 Divezision structure. Form Collins. Colorad, USA. 653 p. (in Eng.).
- [14] Raudkivi A.I. (1984) Basic concepts of sediment transport. JAHR. 86 p. (in Eng.).
- [15] Rayl Pachero-Cebales. (1989) Transport of sediments // Analitikal Solution Journal of Hudralic research. 274:502-503 (in Eng.).
- [16] Utegaliev T.T., Popenko B.V., Kim V., Kuragulov K., Kambatyrov A.S. (1993) River shore water intake structure. AS 1792465, A3. 14931154/15, publ. Bullet. № 4 (in Russ.).
- [17] Popenko B.V., Shrike R.K. (1974) Research of superficial mode of multicirculating sand and gravel trap. Mode of an irrigation and watering technology of agricultural crops in the south of Kazakhstan: Coll. Scien. tr. DGMSI. Tashkent. 66:121-132 (in Russ.).
- [18] Joldassov S.K., Zhulamanov N.J., Mynzhasarov N.J. (2009) The cause of the bays and the ways of their movement // 510 anniversary of M. Kh. Dulati, "VI Dulati readings" International scientific-practical conference. Taraz. P. 221-223 (in Kaz.).
- [19] Koybakov S.M., Joldassov S.K., Utegaliev T.T. (2001) Modeling deformed section of the channel and superficial deferent device // Abstracts of the II Central Asian Int. Conf. Water resources: the potential use of technology and ecology. Almaty. 91 p. (in Russ.).
- [20] Koybakov S.M., Joldassov S.K., (2001) Utegaliev T.T. Determination of the amount of sediment trapped sand trap // Abstracts. Int. Conf. Valihanov's read. P. 91-93 (in Russ.).
- [21] Zanke U. (1982) Grundanlagen der Sedimentbewegung Berlin Heidelberg. P. 53-59 (in Russ.).
- [22] Joldassov S.K., Wysimbaeva J.T., Kasabekov M.I. (2015) Qumtutqıstardıń new design and hydraulic calculations of sand and gravel traps // L. N. Gumilyov Eurasian National University, a scientific journal. 2 :105 (in Kaz.).

**Publication Ethics and Publication Malpractice
in the journals of the National Academy of Sciences of the Republic of Kazakhstan**

For information on Ethics in publishing and Ethical guidelines for journal publication see <http://www.elsevier.com/publishingethics> and <http://www.elsevier.com/journal-authors/ethics>.

Submission of an article to the National Academy of Sciences of the Republic of Kazakhstan implies that the described work has not been published previously (except in the form of an abstract or as part of a published lecture or academic thesis or as an electronic preprint, see <http://www.elsevier.com/postingpolicy>), that it is not under consideration for publication elsewhere, that its publication is approved by all authors and tacitly or explicitly by the responsible authorities where the work was carried out, and that, if accepted, it will not be published elsewhere in the same form, in English or in any other language, including electronically without the written consent of the copyright-holder. In particular, translations into English of papers already published in another language are not accepted.

No other forms of scientific misconduct are allowed, such as plagiarism, falsification, fraudulent data, incorrect interpretation of other works, incorrect citations, etc. The National Academy of Sciences of the Republic of Kazakhstan follows the Code of Conduct of the Committee on Publication Ethics (COPE), and follows the COPE Flowcharts for Resolving Cases of Suspected Misconduct (http://publicationethics.org/files/u2/New_Code.pdf). To verify originality, your article may be checked by the Cross Check originality detection service <http://www.elsevier.com/editors/plagdetect>.

The authors are obliged to participate in peer review process and be ready to provide corrections, clarifications, retractions and apologies when needed. All authors of a paper should have significantly contributed to the research.

The reviewers should provide objective judgments and should point out relevant published works which are not yet cited. Reviewed articles should be treated confidentially. The reviewers will be chosen in such a way that there is no conflict of interests with respect to the research, the authors and/or the research funders.

The editors have complete responsibility and authority to reject or accept a paper, and they will only accept a paper when reasonably certain. They will preserve anonymity of reviewers and promote publication of corrections, clarifications, retractions and apologies when needed. The acceptance of a paper automatically implies the copyright transfer to the National Academy of Sciences of the Republic of Kazakhstan.

The Editorial Board of the National Academy of Sciences of the Republic of Kazakhstan will monitor and safeguard publishing ethics.

Правила оформления статьи для публикации в журнале смотреть на сайте:

[www:nauka-nanrk.kz](http://www.nauka-nanrk.kz)

ISSN 2518-170X (Online), ISSN 2224-5278 (Print)

<http://www.geolog-technical.kz/index.php/en/>

Верстка Д. Н. Калкабековой

Подписано в печать 15.11.2019.
Формат 70x881/8. Бумага офсетная. Печать – ризограф.
19,7 п.л. Тираж 300. Заказ 6.