

ISSN 2518-170X (Online),
ISSN 2224-5278 (Print)

ҚАЗАҚСТАН РЕСПУБЛИКАСЫ
ҰЛТТЫҚ ҒЫЛЫМ АКАДЕМИЯСЫНЫҢ
Қ. И. Сәтпаев атындағы Қазақ ұлттық техникалық зерттеу университеті

Х А Б А Р Л А Р Ы

ИЗВЕСТИЯ

НАЦИОНАЛЬНОЙ АКАДЕМИИ НАУК
РЕСПУБЛИКИ КАЗАХСТАН
Казакский национальный исследовательский
технический университет им. К. И. Сатпаева

NEWS

OF THE ACADEMY OF SCIENCES
OF THE REPUBLIC OF KAZAKHSTAN
Kazakh national research technical university
named after K. I. Satpayev

**SERIES
OF GEOLOGY AND TECHNICAL SCIENCES**

5 (437)

SEPTEMBER – OCTOBER 2019

THE JOURNAL WAS FOUNDED IN 1940

PUBLISHED 6 TIMES A YEAR

ALMATY, NAS RK

NAS RK is pleased to announce that News of NAS RK. Series of geology and technical sciences scientific journal has been accepted for indexing in the Emerging Sources Citation Index, a new edition of Web of Science. Content in this index is under consideration by Clarivate Analytics to be accepted in the Science Citation Index Expanded, the Social Sciences Citation Index, and the Arts & Humanities Citation Index. The quality and depth of content Web of Science offers to researchers, authors, publishers, and institutions sets it apart from other research databases. The inclusion of News of NAS RK. Series of geology and technical sciences in the Emerging Sources Citation Index demonstrates our dedication to providing the most relevant and influential content of geology and engineering sciences to our community.

Қазақстан Республикасы Ұлттық ғылым академиясы "ҚР ҰҒА Хабарлары. Геология және техникалық ғылымдар сериясы" ғылыми журналының Web of Science-тің жаңаланған нұсқасы Emerging Sources Citation Index-те индекстелуге қабылданғанын хабарлайды. Бұл индекстелу барысында Clarivate Analytics компаниясы журналды одан әрі the Science Citation Index Expanded, the Social Sciences Citation Index және the Arts & Humanities Citation Index-ке қабылдау мәселесін қарастыруда. Web of Science зерттеушілер, авторлар, баспашылар мен мекемелерге контент тереңдігі мен сапасын ұсынады. ҚР ҰҒА Хабарлары. Геология және техникалық ғылымдар сериясы Emerging Sources Citation Index-ке енуі біздің қоғамдастық үшін ең өзекті және беделді геология және техникалық ғылымдар бойынша контентке адалдығымызды білдіреді.

НАН РК сообщает, что научный журнал «Известия НАН РК. Серия геологии и технических наук» был принят для индексирования в Emerging Sources Citation Index, обновленной версии Web of Science. Содержание в этом индексировании находится в стадии рассмотрения компанией Clarivate Analytics для дальнейшего принятия журнала в the Science Citation Index Expanded, the Social Sciences Citation Index и the Arts & Humanities Citation Index. Web of Science предлагает качество и глубину контента для исследователей, авторов, издателей и учреждений. Включение Известия НАН РК. Серия геологии и технических наук в Emerging Sources Citation Index демонстрирует нашу приверженность к наиболее актуальному и влиятельному контенту по геологии и техническим наукам для нашего сообщества.

Б а с р е д а к т о р ы
э. ғ. д., профессор, ҚР ҰҒА академигі

И.К. Бейсембетов

Бас редакторының орынбасары

Жолтаев Г.Ж. проф., геол.-мин. ғ. докторы

Р е д а к ц и я а л қ а с ы:

Абаканов Т.Д. проф. (Қазақстан)
Абишева З.С. проф., академик (Қазақстан)
Агабеков В.Е. академик (Беларусь)
Алиев Т. проф., академик (Әзірбайжан)
Бакиров А.Б. проф., (Қырғыстан)
Беспәев Х.А. проф. (Қазақстан)
Бишимбаев В.К. проф., академик (Қазақстан)
Буктуков Н.С. проф., академик (Қазақстан)
Булат А.Ф. проф., академик (Украина)
Ганиев И.Н. проф., академик (Тәжікстан)
Грэвис Р.М. проф. (АҚШ)
Ерғалиев Г.К. проф., академик (Қазақстан)
Жуков Н.М. проф. (Қазақстан)
Қожахметов С.М. проф., академик (Қазақстан)
Конторович А.Э. проф., академик (Ресей)
Курскеев А.К. проф., академик (Қазақстан)
Курчавов А.М. проф., (Ресей)
Медеу А.Р. проф., академик (Қазақстан)
Мұхамеджанов М.А. проф., корр.-мүшесі (Қазақстан)
Нигматова С.А. проф. (Қазақстан)
Оздоев С.М. проф., академик (Қазақстан)
Постолатий В. проф., академик (Молдова)
Ракишев Б.Р. проф., академик (Қазақстан)
Сейтов Н.С. проф., корр.-мүшесі (Қазақстан)
Сейтмуратова Э.Ю. проф., корр.-мүшесі (Қазақстан)
Степанец В.Г. проф., (Германия)
Хамфери Дж.Д. проф. (АҚШ)
Штейнер М. проф. (Германия)

«ҚР ҰҒА Хабарлары. Геология мен техникалық ғылымдар сериясы».

ISSN 2518-170X (Online),

ISSN 2224-5278 (Print)

Меншіктенуші: «Қазақстан Республикасының Ұлттық ғылым академиясы» РҚБ (Алматы қ.).

Қазақстан республикасының Мәдениет пен ақпарат министрлігінің Ақпарат және мұрағат комитетінде
30.04.2010 ж. берілген №10892-Ж мерзімдік басылым тіркеуіне қойылу туралы куәлік.

Мерзімділігі: жылына 6 рет.

Тиражы: 300 дана.

Редакцияның мекенжайы: 050010, Алматы қ., Шевченко көш., 28, 219 бөл., 220, тел.: 272-13-19, 272-13-18,
<http://www.geolog-technical.kz/index.php/en/>

© Қазақстан Республикасының Ұлттық ғылым академиясы, 2019

Редакцияның Қазақстан, 050010, Алматы қ., Қабанбай батыра көш., 69а.

мекенжайы: Қ. И. Сәтбаев атындағы геология ғылымдар институты, 334 бөлме. Тел.: 291-59-38.

Типографияның мекенжайы: «Аруна» ЖК, Алматы қ., Муратбаева көш., 75.

Г л а в н ы й р е д а к т о р
д. э. н., профессор, академик НАН РК

И. К. Бейсембетов

Заместитель главного редактора

Жолтаев Г.Ж. проф., доктор геол.-мин. наук

Р е д а к ц и о н н а я к о л л е г и я:

Абаканов Т.Д. проф. (Казахстан)
Абишева З.С. проф., академик (Казахстан)
Агабеков В.Е. академик (Беларусь)
Алиев Т. проф., академик (Азербайджан)
Бакиров А.Б. проф., (Кыргызстан)
Беспаяев Х.А. проф. (Казахстан)
Бишимбаев В.К. проф., академик (Казахстан)
Буктуков Н.С. проф., академик (Казахстан)
Булат А.Ф. проф., академик (Украина)
Ганиев И.Н. проф., академик (Таджикистан)
Грэвис Р.М. проф. (США)
Ергалиев Г.К. проф., академик (Казахстан)
Жуков Н.М. проф. (Казахстан)
Кожаметов С.М. проф., академик (Казахстан)
Конторович А.Э. проф., академик (Россия)
Курскеев А.К. проф., академик (Казахстан)
Курчавов А.М. проф., (Россия)
Медеу А.Р. проф., академик (Казахстан)
Мухамеджанов М.А. проф., чл.-корр. (Казахстан)
Нигматова С.А. проф. (Казахстан)
Оздоев С.М. проф., академик (Казахстан)
Постолатий В. проф., академик (Молдова)
Ракишев Б.Р. проф., академик (Казахстан)
Сейтов Н.С. проф., чл.-корр. (Казахстан)
Сейтмуратова Э.Ю. проф., чл.-корр. (Казахстан)
Степанец В.Г. проф., (Германия)
Хамфери Дж.Д. проф. (США)
Штейнер М. проф. (Германия)

«Известия НАН РК. Серия геологии и технических наук».

ISSN 2518-170X (Online),

ISSN 2224-5278 (Print)

Собственник: Республиканское общественное объединение «Национальная академия наук Республики Казахстан (г. Алматы)

Свидетельство о постановке на учет периодического печатного издания в Комитете информации и архивов Министерства культуры и информации Республики Казахстан №10892-Ж, выданное 30.04.2010 г.

Периодичность: 6 раз в год

Тираж: 300 экземпляров

Адрес редакции: 050010, г. Алматы, ул. Шевченко, 28, ком. 219, 220, тел.: 272-13-19, 272-13-18,
<http://nauka-nanrk.kz/geology-technical.kz>

© Национальная академия наук Республики Казахстан, 2019

Адрес редакции: Казахстан, 050010, г. Алматы, ул. Кабанбай батыра, 69а.

Институт геологических наук им. К. И. Сатпаева, комната 334. Тел.: 291-59-38.

Адрес типографии: ИП «Аруна», г. Алматы, ул. Муратбаева, 75

E d i t o r i n c h i e f

doctor of Economics, professor, academician of NAS RK

I. K. Beisembetov

Deputy editor in chief

Zholtayev G.Zh. prof., dr. geol-min. sc.

E d i t o r i a l b o a r d:

Abakanov T.D. prof. (Kazakhstan)
Abisheva Z.S. prof., academician (Kazakhstan)
Agabekov V.Ye. academician (Belarus)
Aliyev T. prof., academician (Azerbaijan)
Bakirov A.B. prof., (Kyrgyzstan)
Bespayev Kh.A. prof. (Kazakhstan)
Bishimbayev V.K. prof., academician (Kazakhstan)
Buktukov N.S. prof., academician (Kazakhstan)
Bulat A.F. prof., academician (Ukraine)
Ganiyev I.N. prof., academician (Tadjikistan)
Gravis R.M. prof. (USA)
Yergaliev G.K. prof., academician (Kazakhstan)
Zhukov N.M. prof. (Kazakhstan)
Kozhakhmetov S.M. prof., academician (Kazakhstan)
Kontorovich A.Ye. prof., academician (Russia)
Kurskeyev A.K. prof., academician (Kazakhstan)
Kurchavov A.M. prof., (Russia)
Medeu A.R. prof., academician (Kazakhstan)
Muhamedzhanov M.A. prof., corr. member. (Kazakhstan)
Nigmatova S.A. prof. (Kazakhstan)
Ozdoyev S.M. prof., academician (Kazakhstan)
Postolatii V. prof., academician (Moldova)
Rakishev B.R. prof., academician (Kazakhstan)
Seitov N.S. prof., corr. member. (Kazakhstan)
Seitmuratova Ye.U. prof., corr. member. (Kazakhstan)
Stepanets V.G. prof., (Germany)
Humphery G.D. prof. (USA)
Steiner M. prof. (Germany)

News of the National Academy of Sciences of the Republic of Kazakhstan. Series of geology and technology sciences.

ISSN 2518-170X (Online),

ISSN 2224-5278 (Print)

Owner: RPA "National Academy of Sciences of the Republic of Kazakhstan" (Almaty)

The certificate of registration of a periodic printed publication in the Committee of information and archives of the Ministry of culture and information of the Republic of Kazakhstan N 10892-Ж, issued 30.04.2010

Periodicity: 6 times a year

Circulation: 300 copies

Editorial address: 28, Shevchenko str., of. 219, 220, Almaty, 050010, tel. 272-13-19, 272-13-18,
<http://nauka-nanrk.kz/geology-technical.kz>

© National Academy of Sciences of the Republic of Kazakhstan, 2019

Editorial address: Institute of Geological Sciences named after K.I. Satpayev
69a, Kabanbai batyr str., of. 334, Almaty, 050010, Kazakhstan, tel.: 291-59-38.

Address of printing house: ST "Aruna", 75, Muratbayev str, Almaty

NEWS

OF THE NATIONAL ACADEMY OF SCIENCES OF THE REPUBLIC OF KAZAKHSTAN

SERIES OF GEOLOGY AND TECHNICAL SCIENCES

ISSN 2224-5278

Volume 5, Number 437 (2019), 177 – 188

<https://doi.org/10.32014/2019.2518-170X.140>

UDC 621.38-022.532

ISRSTI 55.09.35

**B. T. Ermagambet¹, M. K. Kazankapova¹, A. V. Borisenko²,
A. T. Nauryzbaeva¹, A. K. Zhenisova¹, L. K. Abylgazina¹**¹LLP «Institute of coal chemistry and technology», Astana, Kazakhstan,²OJSC "Absolute Kazakhstan Company", Karaganda, Kazakhstan.

E-mail: coaltech@bk.ru, maira_1986@mail.ru, asemai_2296@mail.ru,

ms.tanabaeva95@mail.ru, lelya_1501@mail.ru, borisenko@pnt.kz

**SYNTHESIS OF CARBON NANOTUBES BY THE CVD METHOD
ON THE SURFACE OF THE HYDROPHOBIC SHALE ASH**

Abstract. The paper presents a procedure for the synthesis of carbon nanotubes (CNTs) by the CVD (Chemical Vapor Deposition) method with the decomposition of carbon monoxide at a pyrolysis temperature of 800 ° C. Cobalt particles were used as the catalyst, and hydrophobic ash of the oil shale (Kendyrlik field) based on superhydrophobic soot was used as the support for the catalyst. The chemical composition was determined and the morphology of the surface of the samples was studied by using the methods of energy-dispersive X-ray spectroscopy, electron microscopy and Raman scattering. The optimum condition for obtaining CNTs by a catalytic method was established, where the holding time was 120 min at a pyrolysis temperature of 800°C. The yield of carbon nanotubes per unit mass of catalyst was ~ 30%.

Keywords: CNT, catalyst, pyrolysis, shale, ash, soot, CVD method.

Introduction. The last decades were marked by a burst of scientific activity in the development and the study of carbon materials (CM). This was reflected in the purposeful synthesis of allotropic forms of carbon (carbines, fullerenes, nanotubes, circulites, etc.), as well as in the creation of a wide range of porous materials in a series of mixed (transitional) forms of carbon, of practical interest as adsorbents, catalysts and supports for catalysts [1].

The discovery in 1991 of carbon nanotubes (CNTs) has caused a large number of studies devoted to the properties and applications of this modification of carbon in a wide range of fields of science and industry. The improved mechanical characteristics (tensile strength ~ 300 GPa, Young's modulus ~ 1000 GPa) combined with low density (~ 1.8 g/cm³) and nanometer sizes make it possible to consider carbon nanotubes as a promising reinforcing component [2]. Recently, in connection with their unique properties, the greatest interest among nanomaterials is attracted by carbon nanotubes - carbon allotrope with a cylindrical nanostructure.

A cylinder formed from a single graphite sheet is known as a single-walled carbon nanotube and usually has a diameter of about one nanometer to several tens of nanometers (about 30 to 50) and has a length that can be many orders of magnitude greater than the diameter. Multi-walled carbon nanotubes are carbon compounds with layers consisting of coaxially embedded tubes of different diameters (2÷100 nm) or rolled in the form of a scroll from one or more graphene sheets. Due to their structure, CNTs have a number of unique physical properties compared to traditional carbon-based materials. In particular, they are characterized by high tensile strength (exceeding the strength of steel), flexibility, thermal and electrical conductivity. The most interesting property of carbon nanotubes is that they can have conductivity in metallic or semiconductor types, depending on their diameter and chirality [3].

Unique properties of carbon composite have caused their wide distribution in the chemical industry, due to heat resistance, thermal strength, high chemical resistance and specific strength. They are used for

obtaining high-temperature composite materials [4, 5], modified electrodes [6, 7], sorbents, catalytic systems [8-10], as well as in medicine, security and defense devices, power generation and storage devices, transport, communication, computer technology, building materials. Among the most important properties of CNTs, the connection between the geometric structure of a nanotube and its electronic characteristics should be mentioned first [11, 12]. The use of these materials in the electronics industry is explained by the properties of carbon nanotubes, such as mechanical ductility and significant thermal conductivity. Biocompatibility with human and animal tissues causes the possibility of their use in medicine as a carrier for targeted delivery of medicinal agents to target tissues under directed therapy.

The developed surface and structure of CNTs determine their unique electrochemical and sorption properties, when realizing the conditions for their filling with gaseous or liquid substances. The distance between the layers in the multilayer carbon nanotube is close to the corresponding value for crystalline graphite (3.4 nm). This distance is sufficient for placing another substance inside the CNT, and the graphite shell provides a sufficiently good protection of the material contained in it from external chemical or mechanical action. Therefore, CNTs can be considered as a unique storage tank for substances that are in gaseous, liquid or solid state [13].

The prospect of modified CNTs due to the possibility of their effective use as reinforcing fillers of various composites, elements electronic and energy-saving devices, as well as the creation of biocompatible materials in medicine [14].

Methods for synthesizing nanotubes can be divided into non-catalytic and catalytic methods. In the non-catalytic method, carbon nanotubes are synthesized in helium by thermal spraying of a graphite electrode in arc discharge plasma. Alternative methods are the evaporation of a mixture of carbon and transition metals by a laser beam from a target (consisting of a metal alloy with graphite), methods of thermal chemical deposition, plasma-chemical deposition, etc. The catalytic methods are based on the pyrolysis of CO or hydrocarbons in the presence of metallic catalysts [1].

In the catalytic method of CNT synthesis, small particles of different transition metals, for example, elements of group 8, 6B, 5B or a mixture of two, three, four or more elements (including scandium, titanium, vanadium, chromium, manganese, iron, cobalt, nickel, copper, zinc, yttrium, zirconium, niobium, molybdenum, etc.). Non-volatile metal oxides (magnesium, calcium, zirconium, aluminum, lanthanum, silicon, titanium), some salts (calcium carbonate, spinel, perovskite), zeolite, silica gel, airogel, natural clay, amorphous carbon are used as the catalyst support [15].

During the synthesis, nanotubes begin to appear from the catalyst bed, and their thickness directly depends on the size of the catalyzing metal. The surface is heated to high temperatures, and then the carbon-containing gas is supplied (methane, acetylene, ethylene, ethane, propylene, propane, ethyl or propyl alcohol, etc.). As a diluent gas, nitrogen or argon is used. This method of obtaining nanotubes is the most widespread [16, 17].

The main disadvantage of modern catalytic methods for the production of carbon nanotubes is that they consist of several stages. In addition, the catalyst is usually applied in the form of a powder on a substrate, where the main problem is separation from the last nanotubes. In this connection, there is a need to improve the catalytic process for the production of carbon nanotubes, as well as the need for a low-cost method of rapidly obtaining large quantities of high-quality pure CNTs of uniform dimension that would ensure a high yield. Also studies aimed at developing of various catalysts for the complex treatment of gas emissions of industry under more favorable conditions, are strategically important [18].

The purpose of this work is the synthesis of carbon nanotubes (CNTs) by CVD (Chemical Vapor Deposition) method with the decomposition of carbon monoxide in argon, at a pyrolysis temperature of 800 ° C on the surface of the catalyst (10% Co / 5% soot / 85% ash of shale) and study physicochemical properties of the obtained samples. In the CVD method occurs pyrolysis of carbon-containing gas and the dissolution of carbon in the catalyst nanoparticles, which often there are materials with high solubility of carbon (Fe, Co, Ni) [19].

Research method. Samples of carbon nanotubes (CNTs) were obtained in LLP "Institute of Coal Chemistry and Technology» (Astana, Kazakhstan). A catalyst based on cobalt, which was obtained from 0.5 M CoCl₂ in an alcoholic solution in an ultrasonic bath, was used as a stationary layer. The ash part of the oil shale of the Kendyrlík deposit (Kazakhstan) and soot was used as a carrier. To obtain samples of shale ash, the sample was pre-crushed on a hammer mill (Molot-200) to a fraction of 0.1 mm, and then

subjected to heat treatment in a muffle furnace at a temperature of 900 ° C in a current of air for 60 minutes. Samples of carbon black were obtained by electrochemical gassing in an electric field of high voltage on an electrochemical aeroion installation of the series B0-B9 at JSC "Company Absolute Kazakhstan" (Karaganda, Kazakhstan) under the guidance of prof. A.V. Borisenko. The catalyst was then dried in a muffle furnace at 100 ° C for 15 minutes, treated in an inert argon medium at 400 ° C for 1 hour.

The CNT synthesis by gas phase deposition (CVD) was carried out at atmospheric pressure in argon at 800 ° C for 60 and 120 minutes in a horizontal tubular quartz reactor (figure 1).

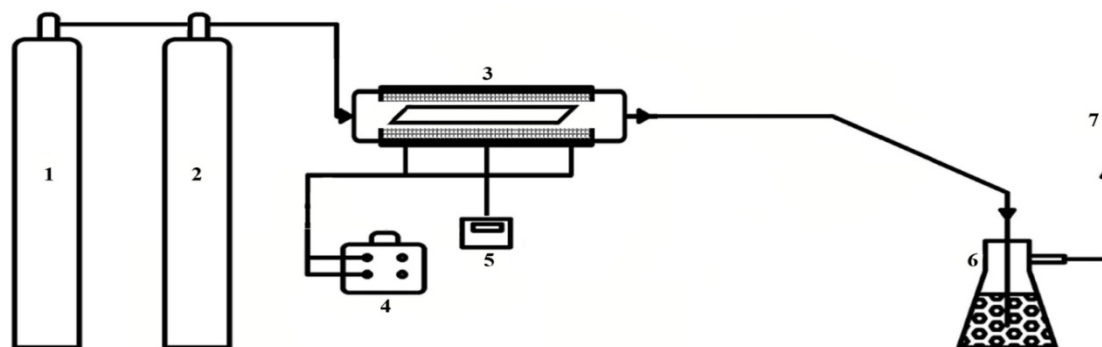

Figure 1 – Schematic diagram of a laboratory installation for the synthesis of CNT:
1 - gas cylinder (argon); 2 - carbon monoxide (CO); 3 - quartz reactor; 4 - LATR;
5 - temperature sensor; 6 - a flask for controlling the gas outlet; 7 - gas outlet

The quartz reactor was heated and cooled in an inert argon medium at a gas velocity of 80 cm³/min. Carbon monoxide was used as the carbon source (carbon-containing raw material), the feed rate was 80-100 cm³/min. 7 g of catalyst was charged to a horizontal cylindrical quartz reactor (3) (with an internal diameter of 30 mm). The reactor is wrapped in a nichrome spiral and insulated with asbestos to heat the furnace. The temperature in the reactor was set by means of a heating element (LATR) (4) and monitored according to the indications of a digital thermal sensor "Aries TRM1" (5) equipped with a thermocouple of the chromel-alumel type introduced into a special pocket of the reactor. The temperature in the reactor was maintained with an accuracy of ± 0.2 °C. Up to 150 °C, the temperature increases at a rate of 2°C/min, after 150°C increases at a rate of 1°C/min.

Element composition, structure and dimension of the catalyst of CNTs were studied on a SEM Phenom XL device (the Netherlands), SEM device (Quanta 3D 200i) with an attachment of energy-dispersive spectrometry (EMF), also on a portable X-ray fluorescence spectrometer S1 Titan (Germany).

Raman spectroscopy was measured using a Solver Spectrum (NT-MDT) apparatus, using a 100x objective and exciting radiation in the visible range from a semiconductor laser $\lambda = 473$ nm. The accumulation time for all spectra was 30 seconds. The original spectra were processed in the Origin Lab program.

Results and discussion. The results of the elemental analysis, presented in table 1, show that the ash part of the shale contains the main compound of silicon, aluminum, calcium and iron, and the carbon content is only 4.6%, due to the intensive release of volatile organic compounds after heat treatment. The elemental composition of the carbon soot indicates the presence of C, O and Ca, which confirms the results of studying the components of soot obtained by the electronic microprobe JCSA 733 by the scientists of Absolute Kazakhstan Company (Karaganda), where the composition (%): C - 87.88; O - 8.85; Al is 1.08; Si - 2.01; S = 0.15 [17].

Electron microscopic images of Kendyrylyk shale ash and soot are presented in figures 2 and 3. Analysis of the the surface morphology of the samples showed that the cleavage surface is represented by structural heterogeneity and has dense formations with strong agglomerates with particle sizes of ~ 155 ± 900 nm. In some places, the cleavage surface is plate-stepped.

Based on the analysis of microphotographs and elemental composition of the soot, it can be concluded that the basis is a structured carbon matrix composed of particles with dimensions of ~80 - 800 nm, which are indicated in micrographs. The spherical shape is due to the fact that the liquid-like particles

Table 1 – Elemental composition of ash from the Kendyryk oil shale and soot

Element	Wt. %	
	Shale ash	Soot
C	4.59	83.67
O	37.33	11.09
Na	0.68	–
Mg	1.37	–
Al	6.99	–
Si	29.91	–
K	2.37	–
Ca	10.54	5.24
Fe	6.20	–

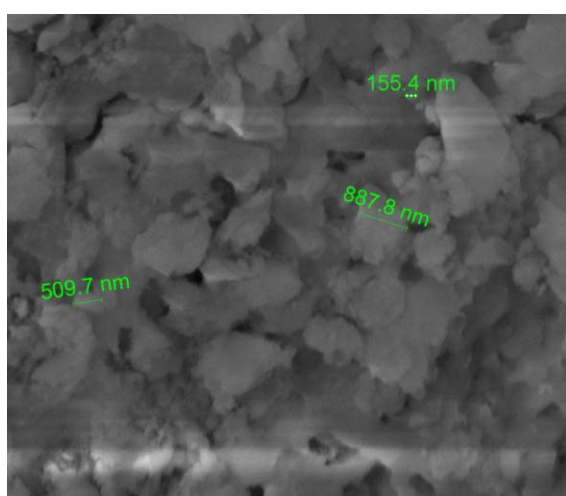

x30 000

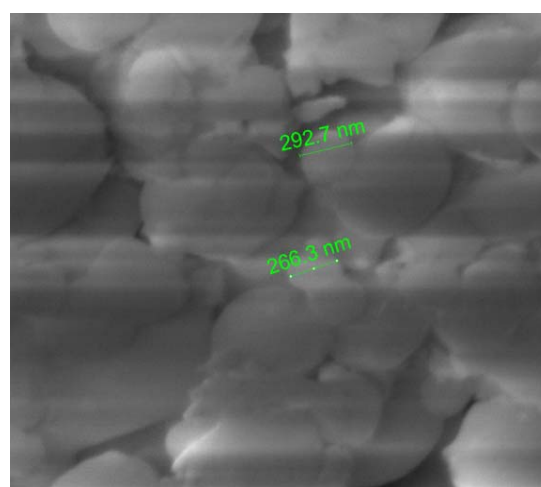

x100 000

Figure 2 – Electron microscopic images of ash from the Kendyryk oil shale

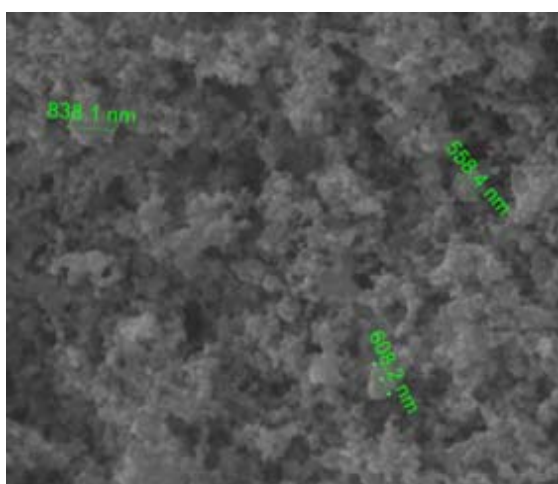

x30 000

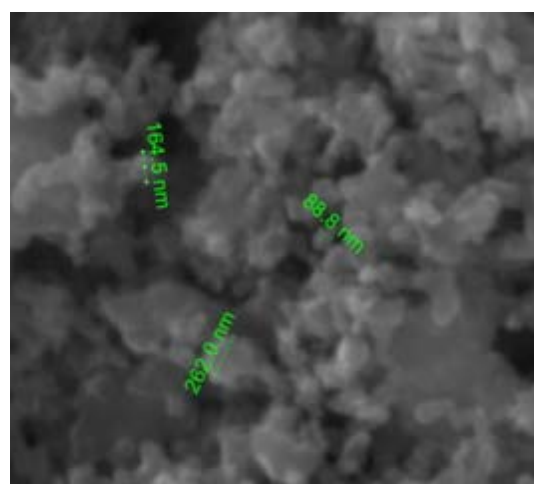

x100 000

Figure 3 – Electron microscopic images of soot

formed by the associates of the graphene clusters are assembled into droplets that are self-compacted by the action of capillary forces [1]. Different microstructural models of the organization of primary particles suggest that in the near-surface layer a part of graphenes is located parallel to their outer surface. As noted [1], primary globules of carbon soot are usually grouped in fairly strong formations of a certain form (primary aggregates), from which less strong secondary aggregates (or agglomerates) are formed. Depending on the method of packing the primary carbon globules in the aggregates, spherical, ellipsoidal, linear and branched carbon soot particles are classified.

Figure 4 shows SEM photographs of the catalyst (10% Co / 5% soot/ 85% ash of shale) after synthesis by the CVD method at a temperature of 800⁰C, the synthesis time of 60 (a) and 120 (b) min.

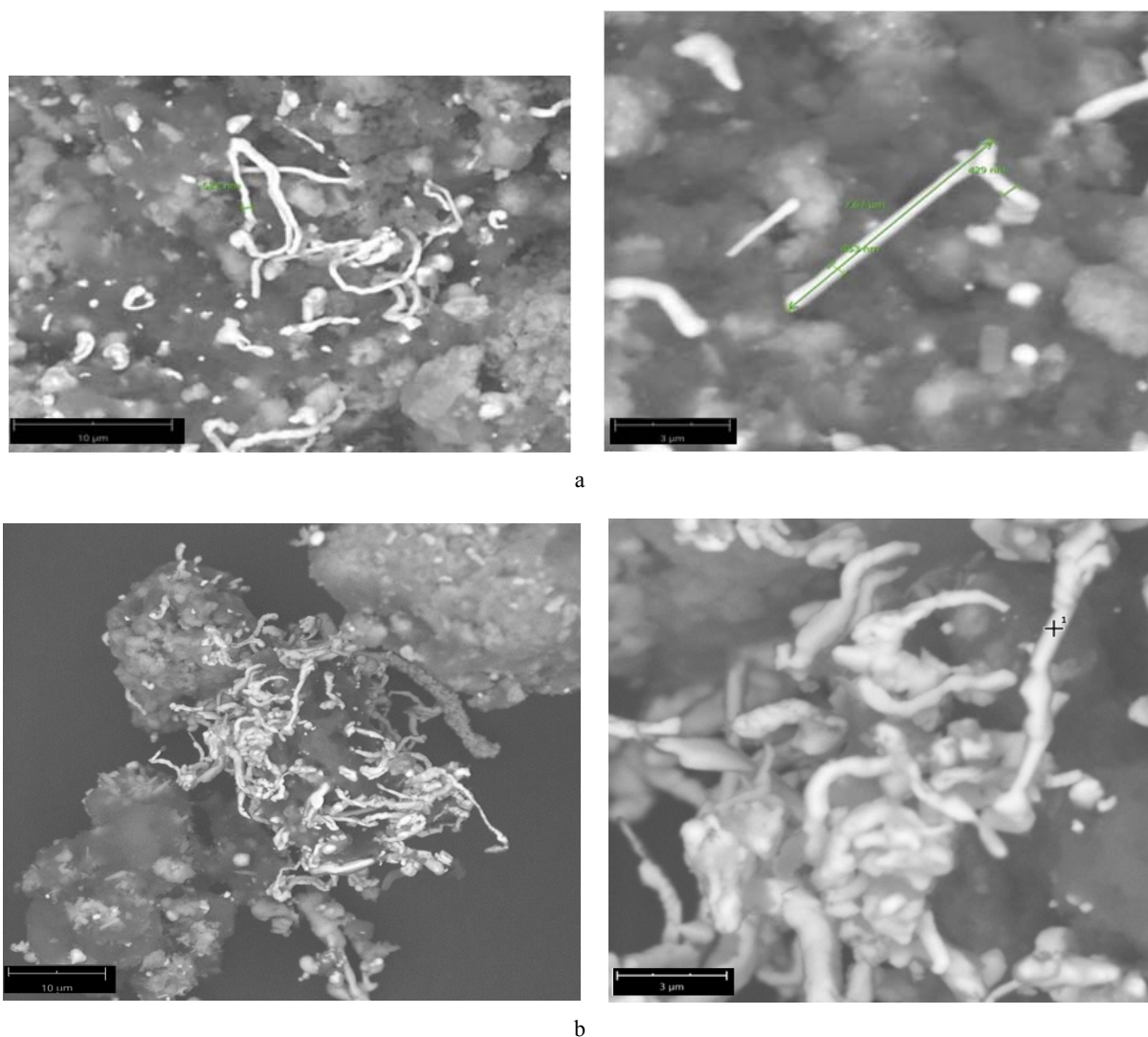

Figure 4 – SEM images of the catalyst after synthesis of CVD, synthesis time:
a – 60 min; b – 120 min

As can be seen from the data obtained on the surface of hydrophobic shale in the presence of Co-particles, carbon filaments (filaments) were formed after the synthesis and a carbon material known as CFC-catalytic fibrous carbon is produced. The process of forming filaments includes the following successive stages: the complete decomposition of the hydrocarbon on one of the faces of the metal with the adsorption of carbon atoms on it, their dissolution and diffusion through the volume of the metallic crystallite, followed by the release and formation of graphene on the other face. In this case, the formed graphene exfoliates from the surface of the metal, giving way to the growth of the next. The scheme of the process of obtaining the CFC from carbon monoxide using the kobolt catalyst is shown in figure 5.

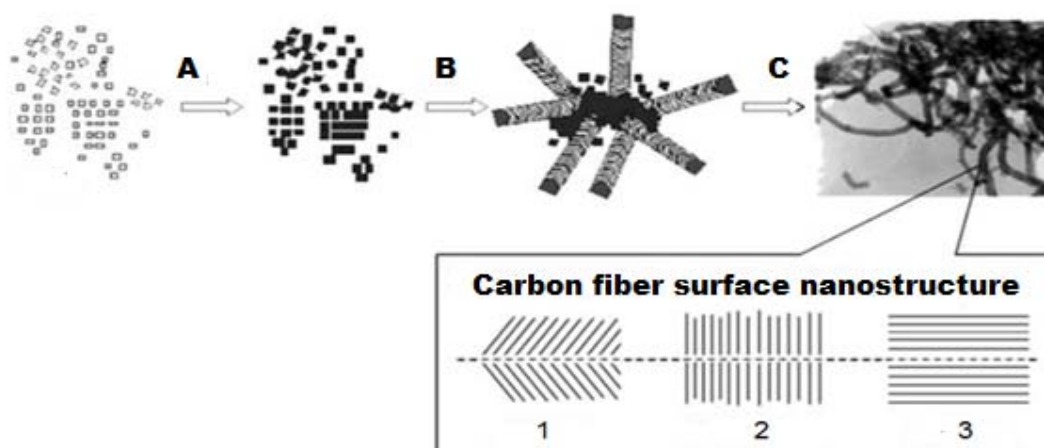

Figure 5 – Scheme for the production of CFC based on Co-catalyst

In stage A, the carbon monoxide decomposes on the surface of the cobalt particles dispersed on the surface of the hydrophobic ash of the oil shale. Carbon is dissolved in metallic cobalt particles to form Co_3C . As a result of the growth of the fibers (stage B), the catalyst particles are separated from one another. Growing fibers (stage C), interwoven into dense tangles, occupy an increasing volume. Note that this feature can be used to produce products of the desired shape from carbon materials. Carbon fibers are known to be graphite-like layers. In this case, the nature of the packing of the layers is determined by the mutual orientation of the faces in the crystallites of the catalyst used. There are three main types of packing layers: 1 - layers in the form of nested one in the other cones - "fish bone"; 2 - layers located perpendicular to the axis of the fiber - "deck of cards"; 3 - nested in one another cylinders, oriented along the axis of the fiber - nanotubes [1]. The derivation of certain types of CFCs depends on the catalytic systems and the synthesis conditions. From the literature data it is known that when using a Co catalyst, nanotubes oriented along the fiber axis are formed, which represent extended structures folded into single or multilayer tubes with a diameter of 100 to 500 nm and a length of about 8 μm . The morphology of the grown CNT is a tubular, curved shape (figure 5). Experimentally it is extremely difficult to synthesize HLCs of the same type with ideal packing of layers.

Table 2 shows the chemical composition of the catalyst after synthesis (10% Co/5% carbon soot/85% ash of shale), which is determined on a portable X-ray fluorescence spectrometer S1 Titan (Germany). The elemental composition confirms the content of the active metal (Co) in the catalyst (9.53%).

Table 2 – Chemical composition of catalyst (wt%)

t , min	SiO_2	Co	Fe_2O_3	CaO	MgO	Al_2O_3	K_2O	MnO	TiO_2	P_2O_5	Cl	S^{daf}	C^{daf}
60	9.97	9.53	4.53	3.09	1.36	0.70	0.31	0.16	0.16	0.03	0.25	0.30	69,55
120	9,58	10,02	4,68	2,81	1,03	0,65	0,22	0,10	0,18	0,01	0,12	0,08	76,68

Figure 6 shows the Raman spectra of the catalyst after synthesis ($t = 60$ min) in the wave interval 200-3200 cm^{-1} . The sample mainly contains carbon in the amorphous state (a) and in the form of graphite (b) [20]. The peak in the 2730 cm^{-1} region indicates the possibility of containing polycrystalline graphite structures - carbon nanotubes (b). The sample contains cobalt oxide (470, 512 cm^{-1}) (c) [21]. A peak in the region of 455 cm^{-1} in figure 6 (d) indicates the presence of compounds containing SiO_4 groups.

Figure 7 shows the Raman spectra of the catalyst after synthesis ($t = 120$ min). As the results showed, the sample is heterogeneous, consists of several components. The main part is carbon in the phase of defective graphite (a). In addition, there are regions containing crystalline graphite structures (possibly carbon nanotubes), as evidenced by narrow peaks at 1360, 1575, 2720 and 2940 cm^{-1} (b). Less intense peaks in the low-frequency region of the spectrum (190, 470, 510, 675 cm^{-1}) shown in figures (b) and (c) may indicate the presence of traces of Co_3O_4 cobalt oxide [22].

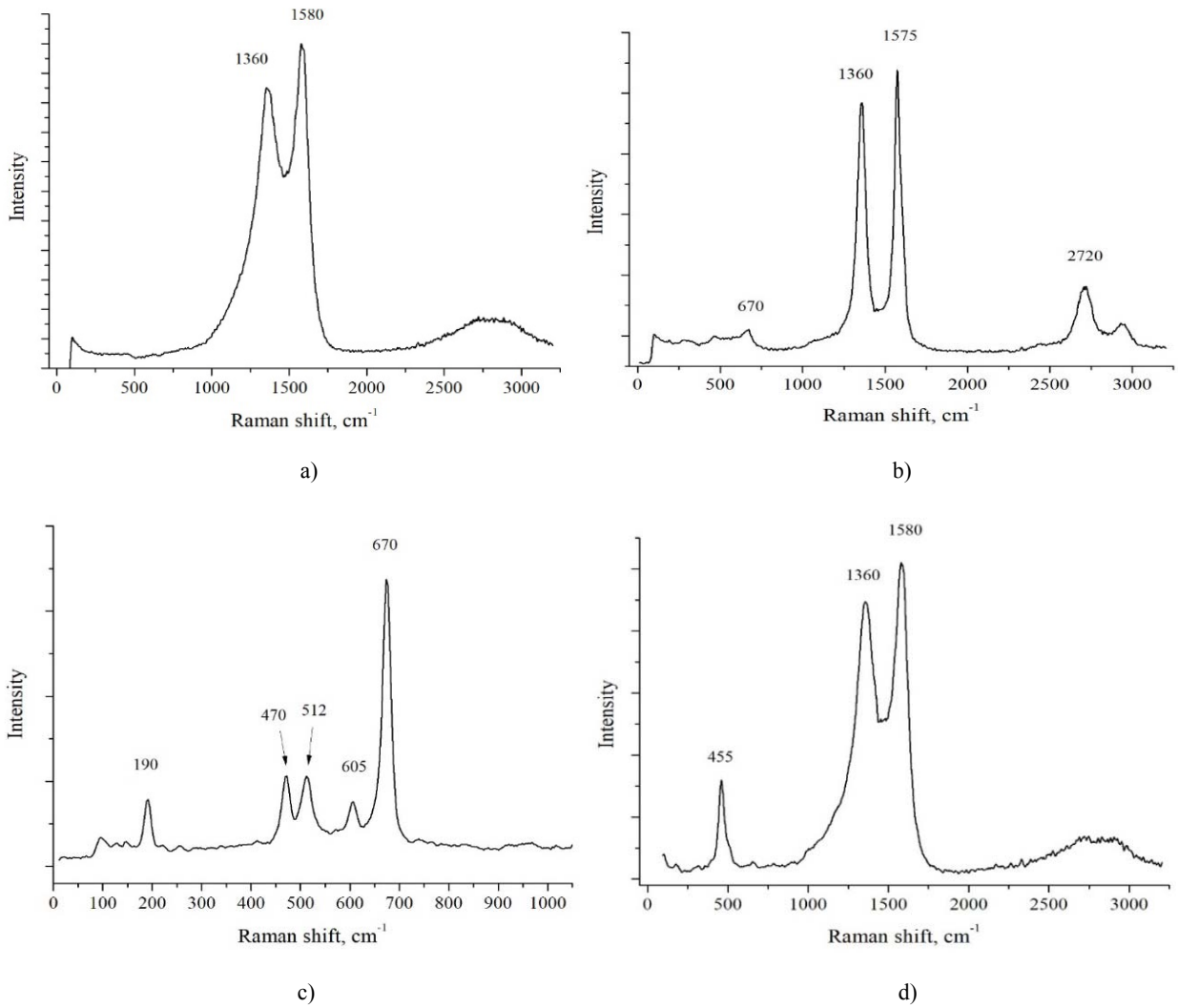
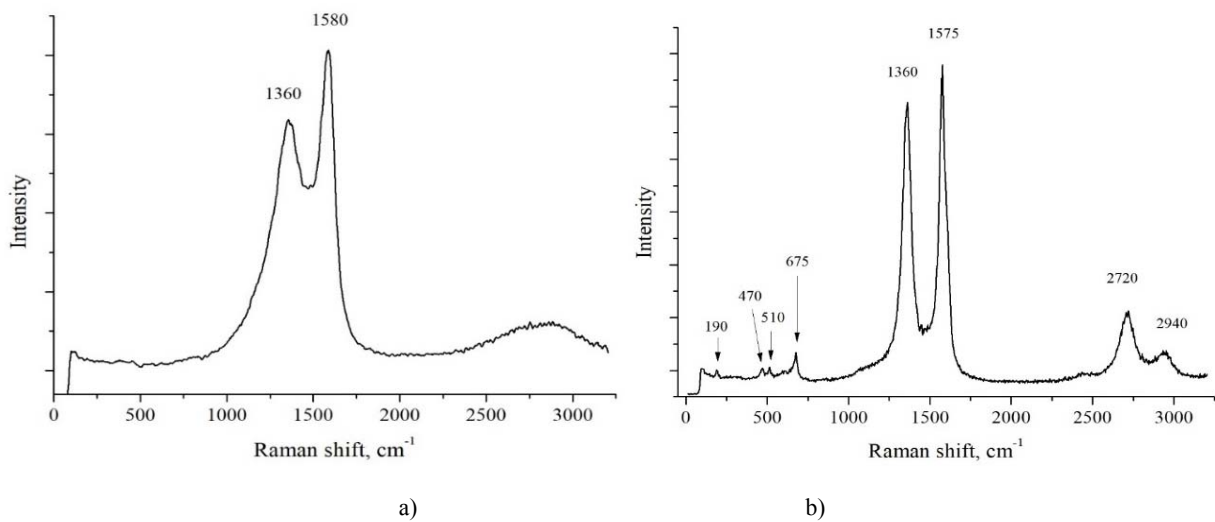
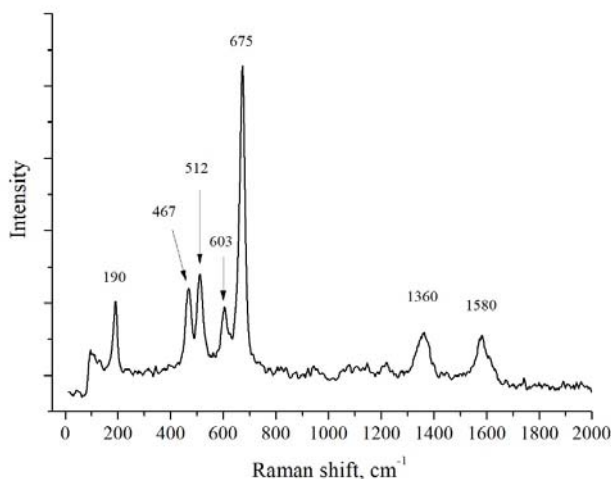

Figure 6 – Raman spectra of the catalyst after CVD synthesis at $t = 60$ min





c)

Figure 7 – Raman spectra of the catalyst after CVD synthesis at $t = 120$ min

After synthesis, carbon materials in the form of a film were formed on the walls of the reactor. The elemental composition of the carbon material showed the presence of 100% pure carbon (figure 8).

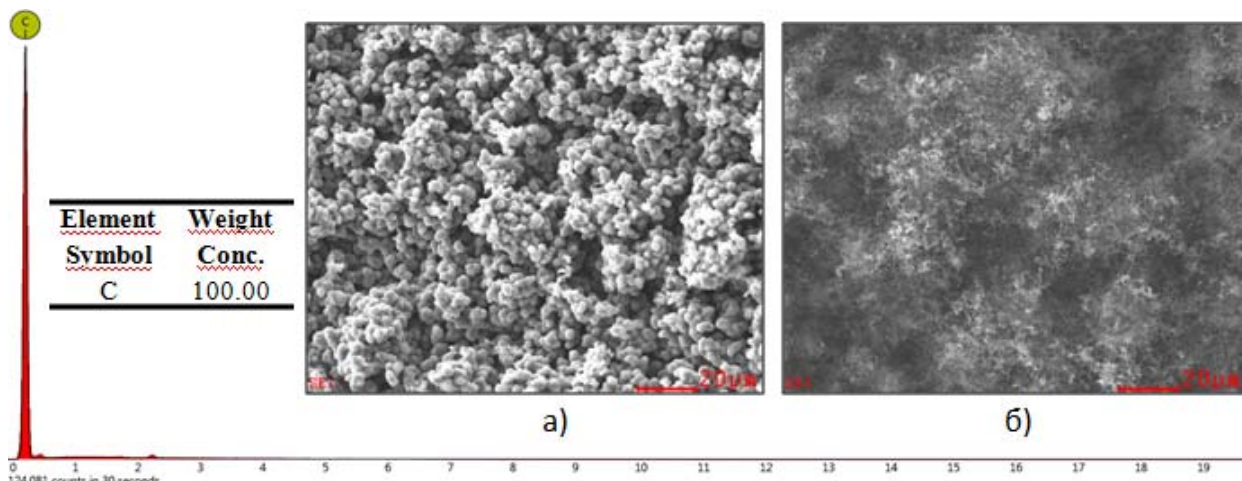

Figure 8 – Elemental composition of the film after synthesis ($T = 800^{\circ}\text{C}$) with a holding time: a - 60 min; b - 120 min

Figure 9 shows SEM photographs of carbon films on the walls of a quartz tube after synthesis by the CVD method at a pyrolysis temperature of 800°C , the synthesis time being 60 min. Carbon material was formed as graphite sheets (also known as graphene), in which the carbon atoms are ordered into sheets with a thickness of 10 to 20 μm . As can be seen from figure 9 (b) the material consists of spherical forms of carbon with dimensions from 200 nm to 1.0 μm . This is due to the fact that during gas-phase thermal decomposition of hydrocarbons, the reaction can proceed through a heterogeneous mechanism with product deposits - pyrolytic carbon (PC) on the equipment walls or other porous materials introduced into the reaction zone.

In this case, the PC is produced in the form of a dense film with a metallic sheen that reproduces all the details of the surface. The process of pyrocarbon formation can be considered as the crystallization of carbon products from the gas phase on the substrate. Growth centers are the embryo of carbon formed from graphenes and their clusters on the surface. During the growth process, carbon atoms from the gas phase interact with the embryos, forming a dense mass. When the pyrolytic layer reaches 10 nm, the influence of the nature of the substrate on the process of its isolation disappears, and the rate of pyrocarbon formation becomes proportional to the surface of the film. Depending on the pyrolysis temperature, the growing carbon layers can form either a turbostratic or graphite-like structure. Pyrocarbon, as a carbon

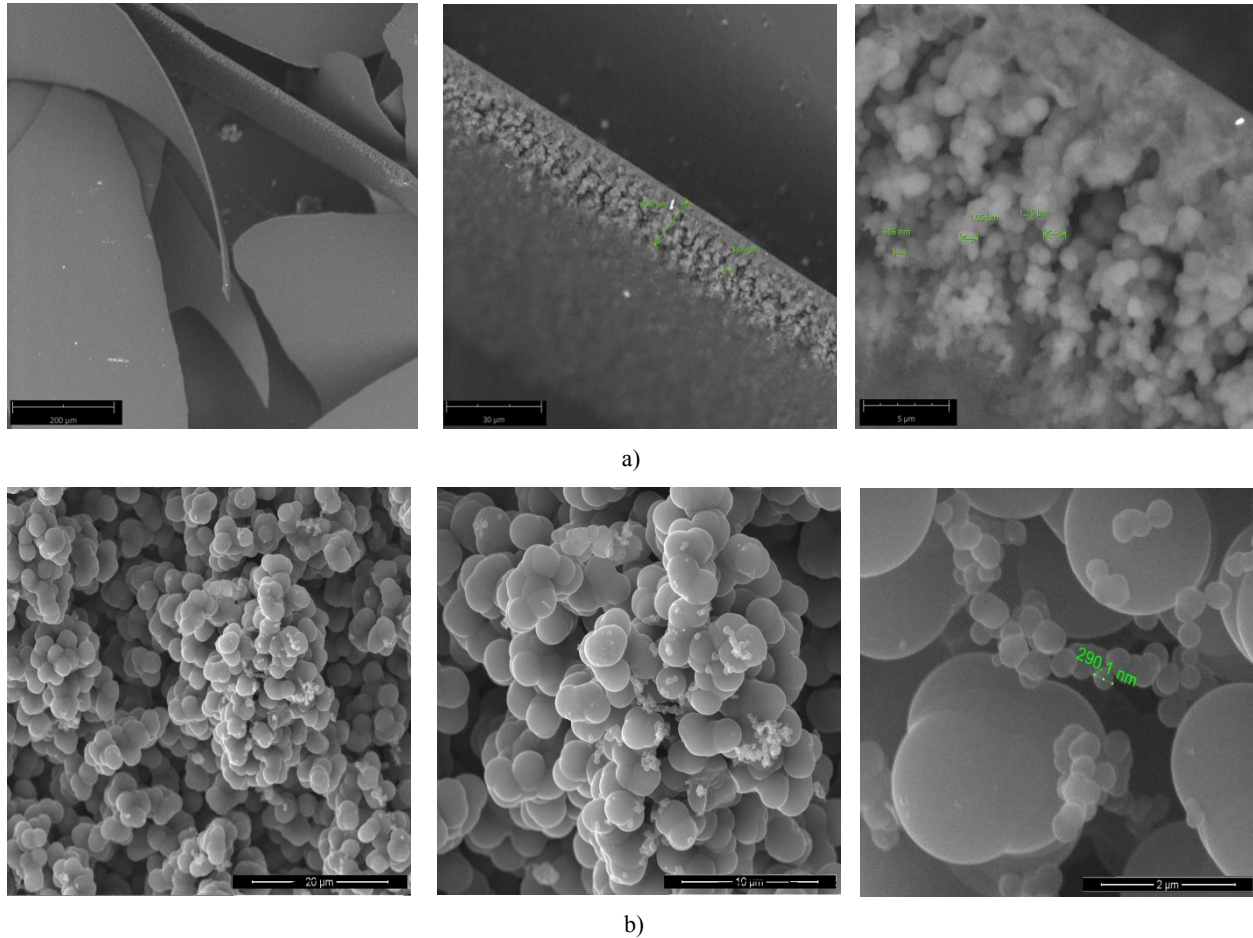

Figure 9 – Electron microscopic images of the film after synthesis at $t = 60$ min, on the device: a - SEM Phenom XL (Netherlands); b - SEM (Quanta 3D 200i)

material, has properties that make it attractive enough for industrial use. However, in view of the fact that it is formed only on free heated surfaces, making any products based on pyrolytic carbon is very difficult. In recent decades, the direction associated with the preparation of carbon-carbon composites has been rapidly developing [1].

An electron microscopic image of a fragment of a carbon material containing CNTs is shown in figure 10, where the retention time of the synthesis was 120 min. Particles of CNT with diameters from 50 to 500 nm are clearly visible, which are folded into a single, seamless seam cylinder. The length of nanotubes can reach tens of micrometers, the end of such a tube can be an open or closed fullerene-like hemisphere. The cylindrical surface of the tubes is formed by hexagons. In real nanotubes, due to the existence of penta- and heptagons, structural defects, the formation of bridges and the sparking of a cylindrical surface are observed [1].

Figure 11 (a) shows the Raman spectrum of the film after synthesis ($t = 60$ min). The sample is homogeneous in structure, a spectrum characteristic of amorphous carbon is observed. Comparison of the Raman spectrum of the investigated sample with Raman spectra for various forms of carbon [1] reveals a similarity (in terms of structural closeness) of the spectrum to nanocrystalline carbon with different quasi-graphite crystallite sizes.

Figure 11 (b) shows the Raman spectrum of the film after synthesis ($t = 120$ min), which is the most typical for carbon nanotubes of a rather high degree of ordering, as evidenced by the peak at 2730 cm^{-1} .

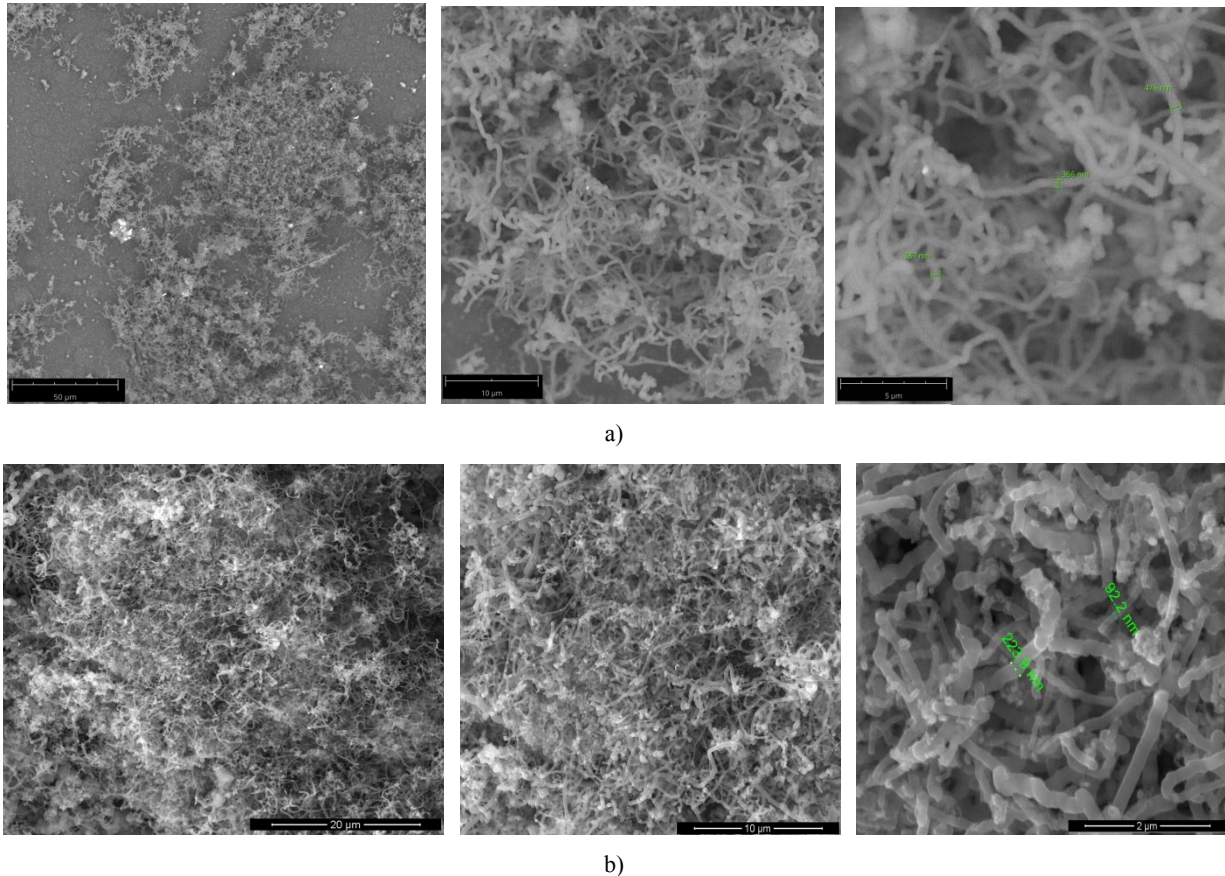

Figure 10 – Electron microscopic images of the film after synthesis at $t = 120$ min, on the device: a - SEM Phenom XL (Netherlands); b - SEM (Quanta 3D 200i)

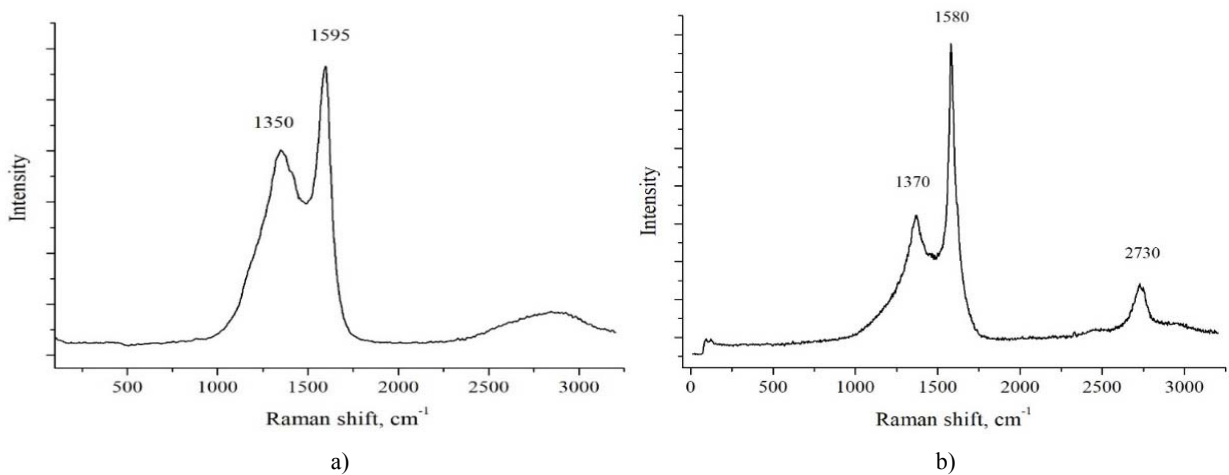

Figure 11 – Raman spectra of the film after CVD synthesis: a - $t = 60$ min; b - $t = 120$ min

Conclusions. Thus, the proposed method of carbon nanotubes is based on the method of chemical (catalytic) vapor deposition, which is the most promising method of industrial production and provides a product with a relatively high multilayeredness and homogeneity of the fraction, which determines the achievement of the strength characteristics required for structural materials. As a result of the high-temperature process, carbon nanotubes (CNTs) were obtained at 800°C (in an inert atmosphere) by the CVD method (chemical Vapor Deposition) with the decomposition of monoxide on the Co catalyst surface, where the hydrophobic ash of the Kendyrlık (Kazakhstan) based on soot. The optimum condition for obtaining CNTs by a catalytic method was established, where the holding time was 120 min at a

pyrolysis temperature of 800 °C. The yield of carbon nanotubes per unit mass of catalyst was ~ 30%. The carbon nanotubes obtained by this method can be used as a power filler in the production of composite and heat-insulating materials.

Acknowledgement. The present work was carried out within the framework of the scientific and technical program No. IRN BR05236359 on the topic: "Scientific and technological support of coal processing and production of high-conversion products of carbon chemistry" and by the project No. IRN AP05130707 on the topic: "Development of technology and creation of production of carbon nanocomposite materials based on mineral domestic raw materials for gas phase and wastewater purification" funded by the Science Committee of the Ministry of Education and Science of the Republic of Kazakhstan.

**Б. Т. Ермағамбет¹, М. К. Казанкапова¹, А. В. Борисенко²,
А. Т. Наурызбаева¹, А. К. Женисова¹, Л. К. Абылгазина¹**

¹«Көмір химиясы және технология институты» ЖШС, Астана, Қазақстан

²ОАО «Компания Absolute Kazakhstan», Қарағанды, Қазақстан

КӨМІРТЕКТІ НАНОТҮТІКШЕНІ CVD ӘДІСІМЕН ГИДРОФОБТЫ СЛАНЕЦ КҮЛІНІҢ БЕТІНДЕ СИНТЕЗДЕУ

Аннотация. Жұмыста көміртекті нанотүтікшені (КНТ) CVD (Chemical Vapor Deposition) әдісімен көміртегі монооксидінің 800 °C пиролиз температурасында ыдырауы нәтижесінде синтездеуге негізделген. Катализатор ретінде кобальт большектері, ал катализаторға тасымалдағыш ретінде супергидрофобты күйе негізіндегі гидрофобты сланец күлі («Кендырлык» кеніші) қолданылды. Энергодисперсионды рентгенді спектроскопия, электронды микроскопия және комбинациялық шашырау әдістері арқылы зерттелген үлгілердің химиялық құрамы және беттік морфологиясы анықталды. КНТ каталитикалық әдіспен алудың оптимальді шарттары анықталды, пиролиз температурасы 800 °C, ұсталу уақыты 120 мин. Катализатордың массасына салыстырғанда көміртекті нанотүтікшенің шығымы ~30 % құрады.

Түйін сөздер: КНТ, катализатор, пиролиз, сланец, күл, күйе, CVD әдісі.

**Б. Т. Ермағамбет¹, М. К. Казанкапова¹, А. В. Борисенко²,
А. Т. Наурызбаева¹, А. К. Женисова¹, Л. К. Абылгазина¹**

¹ТОО «Институт химии угля и технологии», Астана, Казахстан,

²ОАО «Компания Absolute Kazakhstan», Караганда, Казахстан

СИНТЕЗ УГЛЕРОДНЫХ НАНОТРУБОК МЕТОДОМ CVD НА ПОВЕРХНОСТИ ГИДРОФОБНОЙ ЗОЛЫ СЛАНЦА

Аннотация. В работе представлена методика синтеза углеродных нанотрубок (УНТ) методом CVD (Chemical Vapor Deposition) при разложении монооксида углерода при температуре пиролиза 800 °C. В качестве катализатора были использованы частицы кобальта, а в качестве носителя для катализатора применялась гидрофобная зола сланца (месторождения «Кендырлык») на основе супергидрофобной сажи. С использованием методов энергодисперсионной рентгеновской спектроскопии, электронной микроскопии и комбинационного рассеяния определен химический состав и изучена морфология поверхности исследуемых образцов. Установлено оптимальные условия для получения УНТ каталитическим способом, где время выдержки составил 120 мин при температуре пиролиза 800 °C. Выход углеродных нанотрубок на единицу массы катализатора составил ~30 %.

Ключевые слова: УНТ, катализатор, пиролиз, сланец, зола, сажа, метод CVD

Information about authors:

Yermagambet Bolat Toleukhanuly, Doctor of Chemical Science, Professor, Director of LLP "Institute of Coal Chemistry and Technology", Astana, Kazakhstan; bake.yer@mail.ru; <https://orcid.org/0000-0003-1556-9526>

Kazankapova Maira Kuttybaevna, PhD, Senior Researcher of LLP "Institute of Coal Chemistry and Technology", Astana, Kazakhstan; maira_1986@mail.ru; <https://orcid.org/0000-0001-9016-3062>

Borisenko Alexander Vasilyevich, Doctor of Chemical Science, Director of OJSC "Absolute Kazakhstan Company", Karaganda, Kazakhstan; borisenko@pnt.kz; <https://orcid.org/0000-0001-5656-556X>

Nauryzbayeva Asemay Turlanovna, master student, Junior Researcher of LLP "Institute of Coal Chemistry and Technology", Astana, Kazakhstan; asemay_2296@mail.ru; <https://orcid.org/0000-0003-4912-3856>

Zhenisova Akmaral Kamzиеvna, master student, Junior Researcher of LLP "Institute of Coal Chemistry and Technology", Astana, Kazakhstan; ms.tanabaeva95@mail.ru; <https://orcid.org/0000-0001-7529-0223>

Abylgazina Leila Dauletovna, Junior Researcher of LLP "Institute of Coal Chemistry and Technology", Master of Engineering Sciences, Astana, Kazakhstan; lelya_1501@mail.ru

REFERENCES

[1] Romanenko A.V., Simonov P.A. (2007) Carbon materials and their physical and chemical properties: Textbook / Ed. A.S. Noskov. M.: Kalvis. P. 128 (in Russ.).

[2] Rakov E.G. (2006) Nanotubes and fullerenes: A manual. M.: Logos. P. 376 (in Russ.).

[3] Dotsenko O.A., Suslyayev V.I. (2011) Microwave characteristics of composite radio materials // Reports of TUSUR. N 2(24), part 2. December. P. 36-40 (in Russ.).

[4] Abdulkarimova R.G. (2012) Synthesis of carbon-containing composite materials in the combustion mode // Bulletin of KazNU. Ser. chem. 65: 17-21 (in Russ.).

[5] Kopylov A.V. (2013) Determination of heat resistance of high-temperature carbon-containing composite materials with protective coatings // Inter-branch scientific and technical journal FSUE "VIMI". Ser. "Structures made of composite materials. 4: 49-54 (in Russ.).

[6] Frakowiak E., Beguin F. (2001) Carbon materials for the electrochemical storage of energy in capacitors // Carbon. 39: 937-950. DOI. 10.1016/S0008-6223(00)00183-4 (in Eng.).

[7] Zhang Y., Feng H., Wu X., Wang L., Aiqin Zhang, Xia T., Dong H., Li X., Zhang L. (2009) Progress of electrochemical capacitor electrode materials // International journal of hydrogen energy. 34: 4889-4899 (in Eng.).

[8] Plaksin G.V. (2001) Porous carbon materials like sibunit // Chemistry for Sustainable Development. 9: 609-620 (in Russ.).

[9] Lisitsyn A.S., Parmon V.N., Duplyakin V.K., Likhobov V.A. (2006) Current problems and prospects for the development of research in the field of supported palladium catalysts // Russian Journal of Chemical. 50: 140-153 (in Russ.).

[10] Al-Wadhav H.A. (2012) Carbon carriers and synthesis of palladium catalysts based on them // Herald of MIFCT. 7: 3-18 (in Russ.).

[11] Marsh H., Rodrigues-Reinoso F. (2006) Activated carbon. Amsterdam: Elsevier Science & Technology Books. P. 536 (in Eng.).

[12] Dresselhaus M., Dresselhaus G., Elkund P. (1996) Science of fullerene and carbon nanotubes, New York: Academic Press. P. 965 (in Eng.).

[13] Mansurov Z.A., Gabdulin M.T. (2014) White Book on Nanotechnology. Almaty. P. 219 (in Russ.).

[14] Temirgaliyeva T.S., Nazhipkyzy M., Nurgain A., Rahmetullina A., Dinistanova B., Mansurov Z.A. (2017) Synthesis of multiwalled carbon nanotubes by CVD and their functionalization // News of the Academy of sciences of the Republic of Kazakhstan. Series of chemistry and technology. 2017. Vol. 2, N 422. P. 44-50. <https://doi.org/10.32014/2018.2518-1491>. ISSN 2518-1491 (Online), ISSN 2224-5286 (Print) (in Russ.).

[15] Rakov E. (2004) Pyrolytic synthesis of carbon nanotubes and nanofibers // Russian Chemical Journal. 5:12-20 (in Russ.).

[16] Bahome M.C., Jewell L.L., Hildebrandt D., Glasser D., Coville N.G. (2005) Fischer-Tropsch synthesis over iron catalysts supported on carbon nanotubes // Applied Catalysis. 287: 60 (in Russ.).

[17] Temirgaliyeva T., Najipkyzy M., Nurgayin A. (2016) Synthesis of carbon nanotubes by CVD method on the surface of hydrophobic sand // Industry of Kazakhstan. 4: 42-44 (in Russ.).

[18] Tungatarova S.A., Xanthopoulou G., Kaumenova G.N., Zhumabek M., Baizhumanova T.S., Grigorieva V.P., Komashko L.V., Begimova G.U. (2018) Development of composite materials by combustion synthesis method for catalytic reforming of methane to synthesis gas // News of the Academy of sciences of the Republic of Kazakhstan. Series of chemistry and technology. 2018. Vol. 6, N 432. P. 6-15. <https://doi.org/10.32014/2018.2518-1491>. ISSN 2518-1491 (Online), ISSN 2224-5286 (Print) (in Eng.).

[19] Abdullin H.A., Mukashev B.N. (2013) Nanotechnologies in the field of materials science and the production of new materials // Reports of national academy of sciences of the republic of Kazakhstan. 2013. N 5. P. 14-31. <https://doi.org/10.32014/2018.2518-1483>. ISSN 2518-1483 (Online), ISSN 2224-5227 (Print) (in Russ.).

[20] Borisenko A.V. (2007) Scientific fundamentals and practical aspects of electrochemical processes in the gas phase in the zone of dark electrical discharge between the needle cathode and the liquid anode, Monograph. - Karaganda: Publishing house of the University of Karaganda, P. 238. (in Russ.).

[21] John J.F., Alian W., Karla E.K., Bradley L.J., Larry A.H. (2008) Characterization of natural feldspars by Raman spectroscopy for future planetary exploration // The Canadian Mineralogist. 46: 1477-1500. DOI: 10.3749/canmin.46.6.1477 (in Eng.).

[22] Diallo A., Beye A.C., Doyle T.B., Park E., Maaza M. (2015) Green synthesis of Co₃O₄ nanoparticles via Aspalathus linearis: Physical properties // Green Chemistry Letters and Reviews. 8:30-36. DOI: 10.1080/17518253.2015.1082646 (in Eng.).

**Publication Ethics and Publication Malpractice
in the journals of the National Academy of Sciences of the Republic of Kazakhstan**

For information on Ethics in publishing and Ethical guidelines for journal publication see <http://www.elsevier.com/publishingethics> and <http://www.elsevier.com/journal-authors/ethics>.

Submission of an article to the National Academy of Sciences of the Republic of Kazakhstan implies that the described work has not been published previously (except in the form of an abstract or as part of a published lecture or academic thesis or as an electronic preprint, see <http://www.elsevier.com/postingpolicy>), that it is not under consideration for publication elsewhere, that its publication is approved by all authors and tacitly or explicitly by the responsible authorities where the work was carried out, and that, if accepted, it will not be published elsewhere in the same form, in English or in any other language, including electronically without the written consent of the copyright-holder. In particular, translations into English of papers already published in another language are not accepted.

No other forms of scientific misconduct are allowed, such as plagiarism, falsification, fraudulent data, incorrect interpretation of other works, incorrect citations, etc. The National Academy of Sciences of the Republic of Kazakhstan follows the Code of Conduct of the Committee on Publication Ethics (COPE), and follows the COPE Flowcharts for Resolving Cases of Suspected Misconduct (http://publicationethics.org/files/u2/New_Code.pdf). To verify originality, your article may be checked by the Cross Check originality detection service <http://www.elsevier.com/editors/plagdetect>.

The authors are obliged to participate in peer review process and be ready to provide corrections, clarifications, retractions and apologies when needed. All authors of a paper should have significantly contributed to the research.

The reviewers should provide objective judgments and should point out relevant published works which are not yet cited. Reviewed articles should be treated confidentially. The reviewers will be chosen in such a way that there is no conflict of interests with respect to the research, the authors and/or the research funders.

The editors have complete responsibility and authority to reject or accept a paper, and they will only accept a paper when reasonably certain. They will preserve anonymity of reviewers and promote publication of corrections, clarifications, retractions and apologies when needed. The acceptance of a paper automatically implies the copyright transfer to the National Academy of Sciences of the Republic of Kazakhstan.

The Editorial Board of the National Academy of Sciences of the Republic of Kazakhstan will monitor and safeguard publishing ethics.

Правила оформления статьи для публикации в журнале смотреть на сайте:

www.nauka-nanrk.kz

ISSN 2518-170X (Online), ISSN 2224-5278 (Print)

<http://www.geolog-technical.kz/index.php/en/>

Верстка Д. Н. Калкабековой

Подписано в печать 14.10.2019.

Формат 70x881/8. Бумага офсетная. Печать – ризограф.
15,0 п.л. Тираж 300. Заказ 5.