

ISSN 2518-170X (Online),
ISSN 2224-5278 (Print)

ҚАЗАҚСТАН РЕСПУБЛИКАСЫ
ҰЛТТЫҚ ҒЫЛЫМ АКАДЕМИЯСЫНЫҢ
Қ. И. Сәтпаев атындағы Қазақ ұлттық техникалық зерттеу университеті

Х А Б А Р Л А Р Ы

ИЗВЕСТИЯ

НАЦИОНАЛЬНОЙ АКАДЕМИИ НАУК
РЕСПУБЛИКИ КАЗАХСТАН
Казакский национальный исследовательский
технический университет им. К. И. Сатпаева

NEWS

OF THE ACADEMY OF SCIENCES
OF THE REPUBLIC OF KAZAKHSTAN
Kazakh national research technical university
named after K. I. Satpayev

**SERIES
OF GEOLOGY AND TECHNICAL SCIENCES**

2 (434)

MARCH – APRIL 2019

THE JOURNAL WAS FOUNDED IN 1940

PUBLISHED 6 TIMES A YEAR

ALMATY, NAS RK

NAS RK is pleased to announce that News of NAS RK. Series of geology and technical sciences scientific journal has been accepted for indexing in the Emerging Sources Citation Index, a new edition of Web of Science. Content in this index is under consideration by Clarivate Analytics to be accepted in the Science Citation Index Expanded, the Social Sciences Citation Index, and the Arts & Humanities Citation Index. The quality and depth of content Web of Science offers to researchers, authors, publishers, and institutions sets it apart from other research databases. The inclusion of News of NAS RK. Series of geology and technical sciences in the Emerging Sources Citation Index demonstrates our dedication to providing the most relevant and influential content of geology and engineering sciences to our community.

Қазақстан Республикасы Ұлттық ғылым академиясы "ҚР ҰҒА Хабарлары. Геология және техникалық ғылымдар сериясы" ғылыми журналының Web of Science-тің жаңаланған нұсқасы Emerging Sources Citation Index-те индекстелуге қабылданғанын хабарлайды. Бұл индекстелу барысында Clarivate Analytics компаниясы журналды одан әрі the Science Citation Index Expanded, the Social Sciences Citation Index және the Arts & Humanities Citation Index-ке қабылдау мәселесін қарастыруда. Web of Science зерттеушілер, авторлар, баспашылар мен мекемелерге контент тереңдігі мен сапасын ұсынады. ҚР ҰҒА Хабарлары. Геология және техникалық ғылымдар сериясы Emerging Sources Citation Index-ке енуі біздің қоғамдастық үшін ең өзекті және беделді геология және техникалық ғылымдар бойынша контентке адалдығымызды білдіреді.

НАН РК сообщает, что научный журнал «Известия НАН РК. Серия геологии и технических наук» был принят для индексирования в Emerging Sources Citation Index, обновленной версии Web of Science. Содержание в этом индексировании находится в стадии рассмотрения компанией Clarivate Analytics для дальнейшего принятия журнала в the Science Citation Index Expanded, the Social Sciences Citation Index и the Arts & Humanities Citation Index. Web of Science предлагает качество и глубину контента для исследователей, авторов, издателей и учреждений. Включение Известия НАН РК. Серия геологии и технических наук в Emerging Sources Citation Index демонстрирует нашу приверженность к наиболее актуальному и влиятельному контенту по геологии и техническим наукам для нашего сообщества.

Б а с р е д а к т о р ы
э. ғ. д., профессор, ҚР ҰҒА академигі

И.К. Бейсембетов

Бас редакторының орынбасары

Жолтаев Г.Ж. проф., геол.-мин. ғ. докторы

Р е д а к ц и я а л қ а с ы:

Абаканов Т.Д. проф. (Қазақстан)
Абишева З.С. проф., академик (Қазақстан)
Агабеков В.Е. академик (Беларусь)
Алиев Т. проф., академик (Әзірбайжан)
Бакиров А.Б. проф., (Қырғыстан)
Беспәев Х.А. проф. (Қазақстан)
Бишимбаев В.К. проф., академик (Қазақстан)
Буктуков Н.С. проф., академик (Қазақстан)
Булат А.Ф. проф., академик (Украина)
Ганиев И.Н. проф., академик (Тәжікстан)
Грэвис Р.М. проф. (АҚШ)
Ерғалиев Г.К. проф., академик (Қазақстан)
Жуков Н.М. проф. (Қазақстан)
Қожахметов С.М. проф., академик (Қазақстан)
Конторович А.Э. проф., академик (Ресей)
Курскеев А.К. проф., академик (Қазақстан)
Курчавов А.М. проф., (Ресей)
Медеу А.Р. проф., академик (Қазақстан)
Мұхамеджанов М.А. проф., корр.-мүшесі (Қазақстан)
Нигматова С.А. проф. (Қазақстан)
Оздоев С.М. проф., академик (Қазақстан)
Постолатий В. проф., академик (Молдова)
Ракишев Б.Р. проф., академик (Қазақстан)
Сейтов Н.С. проф., корр.-мүшесі (Қазақстан)
Сейтмуратова Э.Ю. проф., корр.-мүшесі (Қазақстан)
Степанец В.Г. проф., (Германия)
Хамфери Дж.Д. проф. (АҚШ)
Штейнер М. проф. (Германия)

«ҚР ҰҒА Хабарлары. Геология мен техникалық ғылымдар сериясы».

ISSN 2518-170X (Online),

ISSN 2224-5278 (Print)

Меншіктенуші: «Қазақстан Республикасының Ұлттық ғылым академиясы» РҚБ (Алматы қ.).

Қазақстан республикасының Мәдениет пен ақпарат министрлігінің Ақпарат және мұрағат комитетінде
30.04.2010 ж. берілген №10892-Ж мерзімдік басылым тіркеуіне қойылу туралы куәлік.

Мерзімділігі: жылына 6 рет.

Тиражы: 300 дана.

Редакцияның мекенжайы: 050010, Алматы қ., Шевченко көш., 28, 219 бөл., 220, тел.: 272-13-19, 272-13-18,
<http://www.geolog-technical.kz/index.php/en/>

© Қазақстан Республикасының Ұлттық ғылым академиясы, 2019

Редакцияның Қазақстан, 050010, Алматы қ., Қабанбай батыра көш., 69а.

мекенжайы: Қ. И. Сәтбаев атындағы геология ғылымдар институты, 334 бөлме. Тел.: 291-59-38.

Типографияның мекенжайы: «Аруна» ЖК, Алматы қ., Муратбаева көш., 75.

Г л а в н ы й р е д а к т о р
д. э. н., профессор, академик НАН РК

И. К. Бейсембетов

Заместитель главного редактора

Жолтаев Г.Ж. проф., доктор геол.-мин. наук

Р е д а к ц и о н н а я к о л л е г и я:

Абаканов Т.Д. проф. (Казахстан)
Абишева З.С. проф., академик (Казахстан)
Агабеков В.Е. академик (Беларусь)
Алиев Т. проф., академик (Азербайджан)
Бакиров А.Б. проф., (Кыргызстан)
Беспаяев Х.А. проф. (Казахстан)
Бишимбаев В.К. проф., академик (Казахстан)
Буктуков Н.С. проф., академик (Казахстан)
Булат А.Ф. проф., академик (Украина)
Ганиев И.Н. проф., академик (Таджикистан)
Грэвис Р.М. проф. (США)
Ергалиев Г.К. проф., академик (Казахстан)
Жуков Н.М. проф. (Казахстан)
Кожаметов С.М. проф., академик (Казахстан)
Конторович А.Э. проф., академик (Россия)
Курскеев А.К. проф., академик (Казахстан)
Курчавов А.М. проф., (Россия)
Медеу А.Р. проф., академик (Казахстан)
Мухамеджанов М.А. проф., чл.-корр. (Казахстан)
Нигматова С.А. проф. (Казахстан)
Оздоев С.М. проф., академик (Казахстан)
Постолатий В. проф., академик (Молдова)
Ракишев Б.Р. проф., академик (Казахстан)
Сейтов Н.С. проф., чл.-корр. (Казахстан)
Сейтмуратова Э.Ю. проф., чл.-корр. (Казахстан)
Степанец В.Г. проф., (Германия)
Хамфери Дж.Д. проф. (США)
Штейнер М. проф. (Германия)

«Известия НАН РК. Серия геологии и технических наук».

ISSN 2518-170X (Online),

ISSN 2224-5278 (Print)

Собственник: Республиканское общественное объединение «Национальная академия наук Республики Казахстан (г. Алматы)

Свидетельство о постановке на учет периодического печатного издания в Комитете информации и архивов Министерства культуры и информации Республики Казахстан №10892-Ж, выданное 30.04.2010 г.

Периодичность: 6 раз в год

Тираж: 300 экземпляров

Адрес редакции: 050010, г. Алматы, ул. Шевченко, 28, ком. 219, 220, тел.: 272-13-19, 272-13-18,
<http://nauka-nanrk.kz/geology-technical.kz>

© Национальная академия наук Республики Казахстан, 2019

Адрес редакции: Казахстан, 050010, г. Алматы, ул. Кабанбай батыра, 69а.

Институт геологических наук им. К. И. Сатпаева, комната 334. Тел.: 291-59-38.

Адрес типографии: ИП «Аруна», г. Алматы, ул. Муратбаева, 75

E d i t o r i n c h i e f

doctor of Economics, professor, academician of NAS RK

I. K. Beisembetov

Deputy editor in chief

Zholtayev G.Zh. prof., dr. geol-min. sc.

E d i t o r i a l b o a r d:

Abakanov T.D. prof. (Kazakhstan)
Abisheva Z.S. prof., academician (Kazakhstan)
Agabekov V.Ye. academician (Belarus)
Aliyev T. prof., academician (Azerbaijan)
Bakirov A.B. prof., (Kyrgyzstan)
Bespayev Kh.A. prof. (Kazakhstan)
Bishimbayev V.K. prof., academician (Kazakhstan)
Buktukov N.S. prof., academician (Kazakhstan)
Bulat A.F. prof., academician (Ukraine)
Ganiyev I.N. prof., academician (Tadjikistan)
Gravis R.M. prof. (USA)
Yergaliev G.K. prof., academician (Kazakhstan)
Zhukov N.M. prof. (Kazakhstan)
Kozhakhmetov S.M. prof., academician (Kazakhstan)
Kontorovich A.Ye. prof., academician (Russia)
Kurskeyev A.K. prof., academician (Kazakhstan)
Kurchavov A.M. prof., (Russia)
Medeu A.R. prof., academician (Kazakhstan)
Muhamedzhanov M.A. prof., corr. member. (Kazakhstan)
Nigmatova S.A. prof. (Kazakhstan)
Ozdoyev S.M. prof., academician (Kazakhstan)
Postolatii V. prof., academician (Moldova)
Rakishev B.R. prof., academician (Kazakhstan)
Seitov N.S. prof., corr. member. (Kazakhstan)
Seitmuratova Ye.U. prof., corr. member. (Kazakhstan)
Stepanets V.G. prof., (Germany)
Humphery G.D. prof. (USA)
Steiner M. prof. (Germany)

News of the National Academy of Sciences of the Republic of Kazakhstan. Series of geology and technology sciences.

ISSN 2518-170X (Online),

ISSN 2224-5278 (Print)

Owner: RPA "National Academy of Sciences of the Republic of Kazakhstan" (Almaty)

The certificate of registration of a periodic printed publication in the Committee of information and archives of the Ministry of culture and information of the Republic of Kazakhstan N 10892-Ж, issued 30.04.2010

Periodicity: 6 times a year

Circulation: 300 copies

Editorial address: 28, Shevchenko str., of. 219, 220, Almaty, 050010, tel. 272-13-19, 272-13-18,
<http://nauka-nanrk.kz/geology-technical.kz>

© National Academy of Sciences of the Republic of Kazakhstan, 2019

Editorial address: Institute of Geological Sciences named after K.I. Satpayev
69a, Kabanbai batyr str., of. 334, Almaty, 050010, Kazakhstan, tel.: 291-59-38.

Address of printing house: ST "Aruna", 75, Muratbayev str, Almaty

NEWS

OF THE NATIONAL ACADEMY OF SCIENCES OF THE REPUBLIC OF KAZAKHSTAN

SERIES OF GEOLOGY AND TECHNICAL SCIENCES

ISSN 2224-5278

Volume 2, Number 434 (2019), 217 – 224

<https://doi.org/10.32014/2019.2518-170X.57>

UDC 004.032.26

MRNTI 28.23.37

**M. N. Kalimoldayev¹, E. I. Suleimenov^{2,5}, I. T. Pak¹,
E. S. Vitulyova², Z. S. Tasbulatova², V. N. Yevstifeyev², G. A. Mun^{4,5}**

¹Institute of Information and Computational Technologies, Almaty, Kazakhstan,

²Almaty University of Power Engineering and Telecommunications, Almaty, Kazakhstan,

³The University of Birmingham, United Kingdom, Birmingham,

⁴Al-Farabi Kazakh National University, Almaty, Kazakhstan,

⁵National Engineering Academy of the Republic of Kazakhstan.

E-mail: esenych@ya.ru, pak.it@mail.ru, k.suleymenova@bham.ac.uk, lizavita@list.ru,
z.tasbulatova@gmail.com; yvladimirn@gmail.com, mungrig@ya.ru.

TO THE QUESTION OF PHYSICAL IMPLEMENTATION OF OPTICAL NEURAL NETWORKS

Abstract. The practical realization of optical neural networks with a small number of elements is considered. It is presented the application of the optical neural networks to the systems of adaptive optics. In this case, the usage pattern of the neural network assumes the impact on changes in the characteristics of the system. The application of adaptive optical system is a good example to design the automatic adjustment of the parabolic reflector when the sun moves across the sky. Since the parabolic reflectors used in solar power plants do not provide the necessary economic efficiency, this problem solving is relevant and actual. Using the adaptive optics systems allows to solve this problem due to the transition to light parabolic reflectors made of thin polymer film with a mirror coating. Fixing the shape of the parabolic reflector is ensured by the balloon system filled with a gas at the pressure slightly above atmospheric. The small weight of the parabolic reflector makes possible to use the servo-driven elements to develop a small torque. In particular, the balloon regulating elements are changing the volume of gas by solar heating. In this case, the controlling is created by focusing a portion of the solar energy entering the system on servo-driven elements. The paper is considering the different designs of optical neural networks. The optical neural network with thin optical transparency as a matrix of weights is presented as the most effective and easiest in implementation. In this case, each light source corresponding to the neurons of the first layer of the network is forming several images and the linear set of sources is transforming into the two-dimensional one. Optical summation of this matrix by columns ensures the performance of additive summation and this sets the work of the optical neurons on the second layer.

Keywords: neural network, optical signal, alternative energy, reflectors, control signals.

The work [1] outlines a strategy for the development of artificial intelligence systems in the Republic of Kazakhstan. A distinction of this strategy lies in the integrated interdisciplinary approach to the creation of all components of artificial intelligence systems (AI), focused on a wide range of practical applications, including the creation of molecular informatics systems [2, 3] based on the latest achievements in the field of physical chemistry of polymers [4, 5]. As is known, one of the most important areas of AI systems development is artificial neural networks (ANNs). Currently, ANNs are mainly presented as computer models and their physical implementation have to be considered [6-8].

As shown in [9, 10], one of the most promising directions for the physical implementation of ANNs lies in the creation of optical intelligent systems. An important step on this path is the development of optical ANNs. The advantage is presented in the possibility to work directly with a two-dimensional data array, which corresponds to the distribution of the light field in the input plane of the optical system. However, the development of optical neural networks is currently faced with well-defined difficulties.

One of them is the limitation of their practical application. Thus, this work will show an unexpected application of optical neural networks in the field of solar energy.

Namely, at present, solar energy is developing in several directions. In particular, despite significant progress in increasing the efficiency of solar photovoltaic panels, the development of solar collectors and concentrators remains relevant [11-14]. The design of such systems can be quite complex (including from the point of view of the used optical circuits [15]), however, devices based on the use of the historically first radiation concentrator - a parabolic reflector [16, 17] continue to be discussed. (The latter can be used, including, in combination with solar photovoltaic panels [18].)

The disadvantage of this type of systems is in sufficiently large weight of reflectors, which are being increased by area increasing. Accordingly, the large expenditure of energy is required on targeting the optical axis of the reflector to the Sun. In addition, the production of the reflector with typical characteristics is quite difficult; as a result, the cost of the energy increases. Moreover, the typical systems described in the literature [16, 17] are required to use servo-driven mechanisms, as well as rather complex control systems that ensure the tracking of the Sun's movement across the sky. As shown in [19], the problem of guidance of solar power systems in the Sun is very serious, and its decision to continue to be expended considerable effort. So, [20], in particular, describes a guidance system in which continuous movement of a solar power plant takes place, regardless of whether the Sun is in direct view or hidden behind clouds.

In terms of energy consumption, the most effective way to ensure the required orientation of the reflector in space lies in using thin polymer films. The scheme of the corresponding system is shown in figure 1.

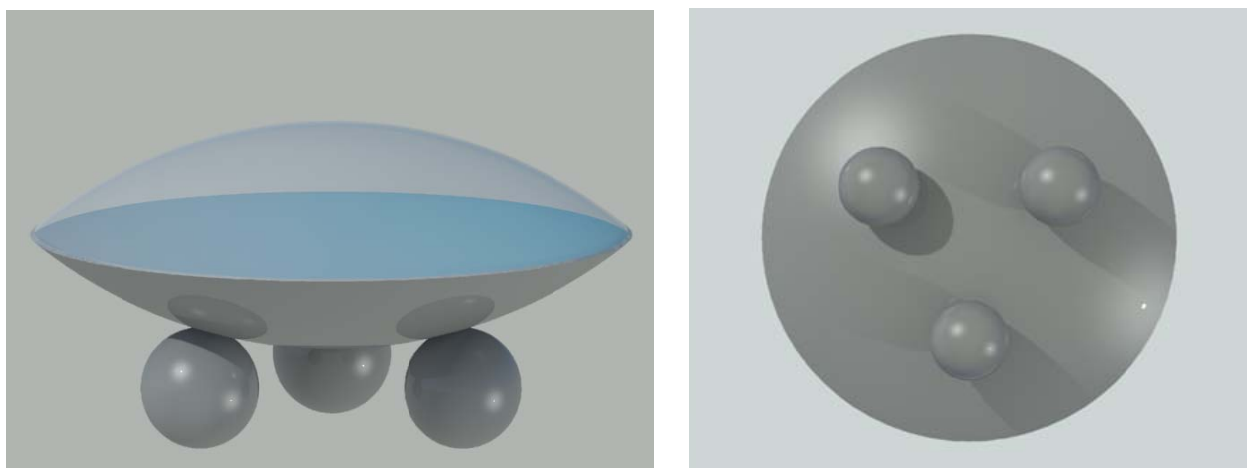

Figure 1

The reflector is presented as a gas-filled cylinder made of two parts. One part (1) is the reflector itself, which made of a polymer film with a reflective coating. The upper part is transparent and serves to ensure the given shape to the system when it is filled with gas at the pressure slightly higher than atmospheric (3). This Figure also schematically shows balloon servo-driven mechanisms (2).

Taking into consideration a small weight of the reflector itself, which can even be reduced due to the Archimedean force (which arises due to the fact that the gas inside the cylinder formed by the films (1) and (3) is heated during the work), it can be used the servo-mechanisms that perform only relatively small mechanical work.

In particular, such servomechanisms can be presented as balloon assemblies from polymeric elastic shell filled with gas or vapors of a slightly volatile liquid. When the gas is heated or the liquid is evaporated, the pressure will grow, the shell will be stretched; as a result, the system is able to ensure the rotation of the reflector to the required angle, as illustrated in figure 2. To protect the system from external influences (in particular from wind exposure), it is advisable to place it inside the containment shell as shown in figure 2. Here is shown the reflector (1) which is attached through the rods (3) to the assembly where the working body (2) heated by focused solar radiation is placed.

The entire system is situated inside the transparent protective sheath (4), which can also be made as a balloon from the transparent polymer film and filled with gas at a pressure slightly above atmospheric. Figure 2b shows the position of the focusing system during the rotation due to the servo-driven balloon system, which changes its volume heating by solar radiation. It should be emphasized that in this figure the servo-driven balloon system is shown schematically in the form of spheres for the sake of clarity; however, it is more convenient to use more complex geometry in order to optimize the response of systems to changes of temperature.

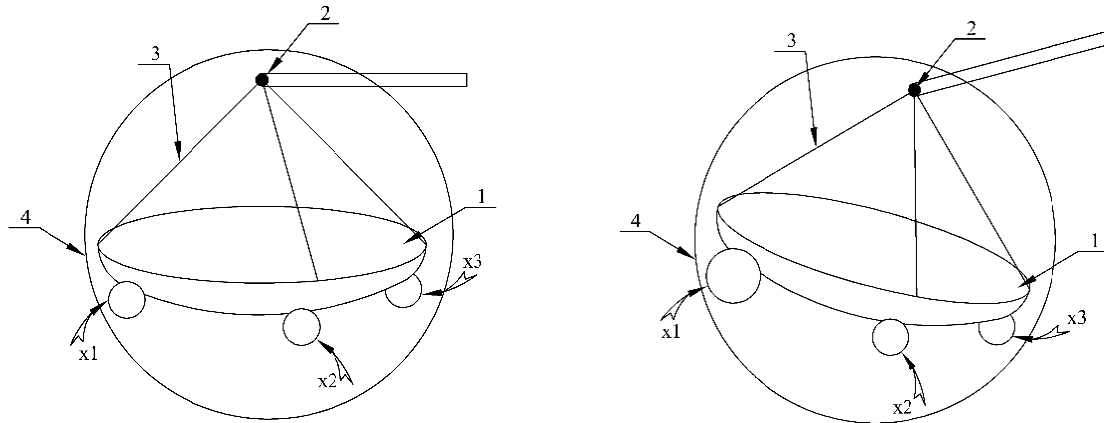

Figure 2a, 2b

Thus, the balloon parabolic reflectors really allow to make a device from the most cheap and light-weight materials that can be used in solar energy with a significant reduction of the cost.

The important element of the system is to provide the change in the orientation of the reflector while the Sun is moving across the sky. As noted above, the typical systems use control of complex software systems that take into account the geographical location of the reflector. However, this task can also be solved by the systems of adaptive optics, the system that provides automatic orientation of the reflector due to the temperature changes of the balloon system (in this very case). In other words, part of the solar energy entering the system is directed to servo-driven cylinders, which ensures the correct orientation of the reflector in automatic mode without using any additional control devices.

Thus, the considered system works due to the unequal heating of the three control elements. Since the temperature of the control elements is determined by solar radiation this example provides a convenient illustration of the possibility to use practically the optical neural networks. Indeed, the solar radiation from the control elements must be transformed to ensure the heating all three elements corresponding to the specified functioning of the device as a whole.

It should be emphasized that this example is used only to demonstrate the fact that the optical neural networks can be used to immediately generate control signals. It is significant that in this very case there is no need to use nonlinear optical elements that have to be introduced into the optical neural network when it is considered as a system intended only for information processing. In this case, the control assemblies with control optical (thermal) signals act as the nonlinear elements.

Neural networks are currently primarily used as information processing means. The vast majority of existing neural networks is presented as nothing more than computer programs.

At the same time, as it is shown in this work, the neural networks, even with a relatively small number of elements, can be used in automatic control systems as the assemblies that ensure the formation of effects that physically implement one or another algorithm of executive programs.

Optical neural network (in case of the physical implementation) has the advantage to work directly with two-dimensional data array. This is illustrated in figure 1, which schematically shows three light sources acting as neurons of the first layer and three radiation detectors acting as nonlinear elements of the neurons of the second layer of the network. In this case, the radiation from each source by three different optical elements is focused on each receiver. In order not to clutter up the drawing, it is shown the course of the rays only for the 1st and 3rd optical elements associated with each light source.

In the situation when the focusing optical elements have different transmission functions, it is easy to see that this kind of system performs additive summation of the original signals. In other words, the focusing elements together with the radiation detectors perform the same operations as the formal neurons of any classical artificial neural network.

Figure 3 is presented only to illustrate the nature of the operation of the optical neural networks. The advantage of this system lies in only visibility, and its technical implementation is very complicated due to the necessity of using a large number of focusing elements. It is much more easier to develop the physical implementation of the optical neural network by using the Fourier transforms of the lens (figure 4).

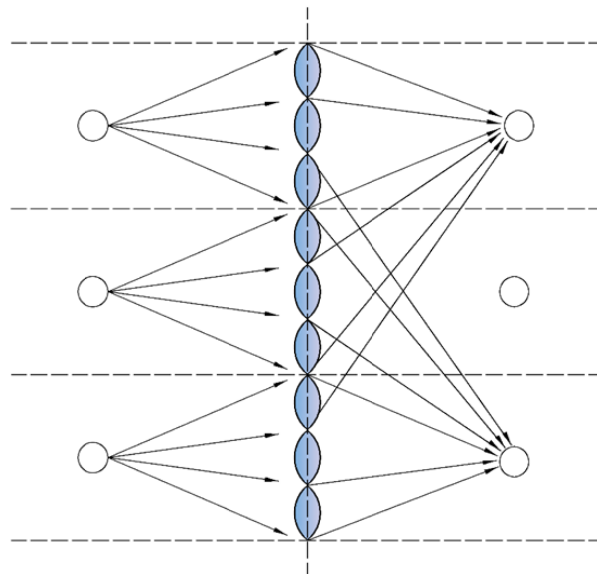

Figure 3

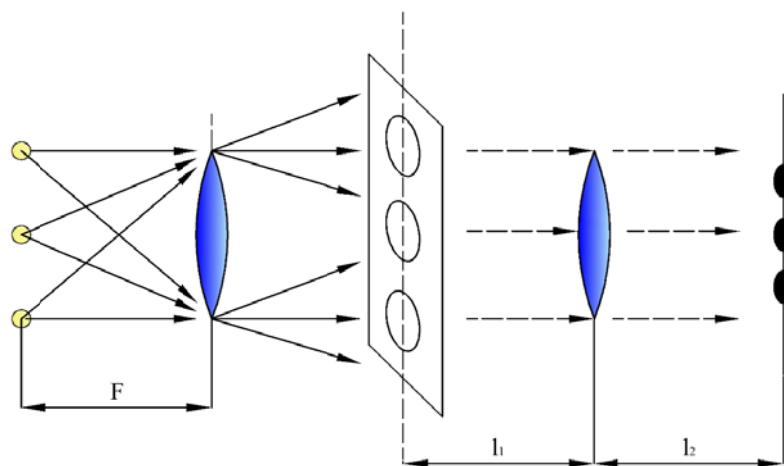

Figure 4

The figure also shows the three light sources that are placing in the focal plane of the input lens. The lens converts the radiation of each point source into a plane wave, which propagates at a certain angle to the optical axis; this angle is determined by the distance from the point source to the optical axis. Accordingly, the distribution of light intensity occurs at each point of the screen located behind the lens L1; it is determined by the superposition of the contributions from all these plane waves. Further, it is possible to ensure the construction of the screen's holes by using the L2 lens. The radiation intensity corresponding to this image will also be the sum of the contributions from point sources.

From the point of using the system as a neural network, the disadvantage lies in the fact that the contribution from point sources does not have adjustable weights. It can be eliminated by providing a non-uniform diagram of the point sources used as the neurons of the first layer.

However, providing this diagram of the light point sources would not be a non-trivial task. Thus, taking into consideration that at the early stages of the implementation of optical neural networks there is no need to work with a large number of neurons, the following modification of the optical ANN is proposed.

The basis of this modification is about the optical element shown in figure 5. This optical element is actually made as a set of lenses arranged in a ruler from the single blank by the method of stamping or casting.



Figure 5

By applying such element, it is possible to develop the optical neural network using the fact that the set of light sources playing the role of inputs to neural networks located along a certain line appears as the set of dimension 1. This set can be displayed on the screen that appears as the set of dimension 2. This condition meets the nature of the connection between the number of network neurons and the number of weight coefficient; the number of weights is equal to the square of the number of neurons in the Hopfield neuroprocessor.

This very implementation of the system is shown in figure 6. Figure 6a shows the nature of the radiation conversion by the set of point sources of the optical element, which is shown in figure 5. The figure emphasizes that the optical element creates an image of sources that are also located along a straight line.

Figure 6b demonstrates how the optical elements are used to expand the linear set of sources into the two-dimensional set. The top view of the system is considered in the Figure. The number (1) marks the entire line of the optical sources of the original radiation. The number (2) marks the set of optical elements that is shown in figure 5. The system also includes the screen made as optical transparency, focusing elements (4) and radiation receivers (5) presented as the control nodes of the device (for example, nodes providing the orientation of the parabolic mirror on the Sun). Each optical element (2) creates its own system of images of the point sources of the screen (3).

The result of this conversion is illustrated in figure 6c. It shows the individual columns formed by the images of the original light sources presented because of the construction of the image elements (2). The screen (3) is made as optical transparency and the transmittance of its individual sections is non-uniform. In an extreme case, this screen may be made as a mask with holes corresponding to the non-zero weights of the neural network.

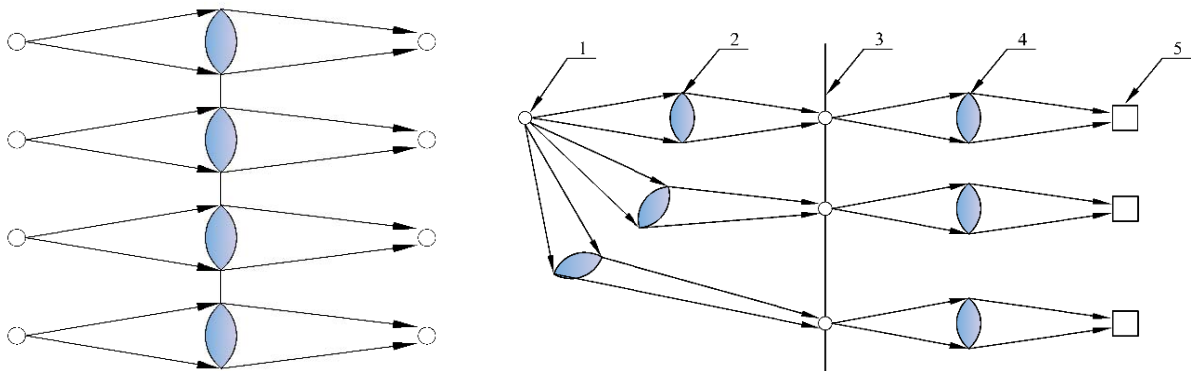

Figure 6a, 6b

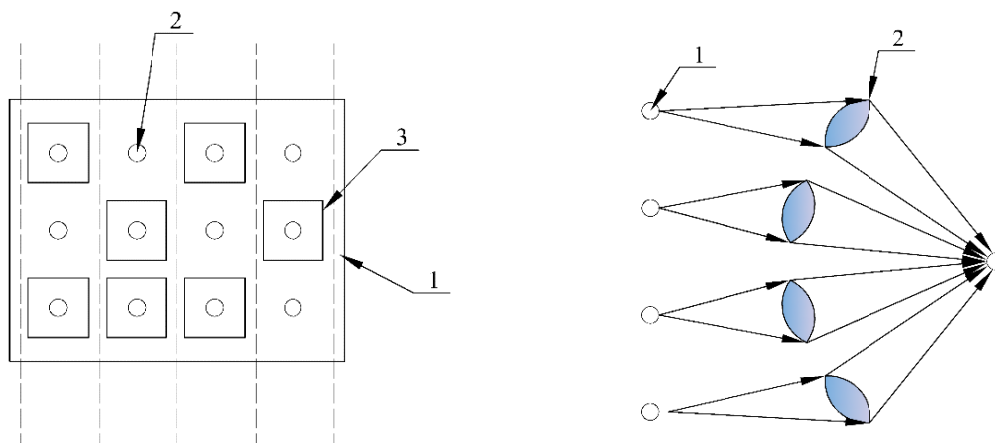

Figure 6c, 6d

Hereafter, the radiation generated by each column enters the focusing elements (4) which form the image on the receivers (5). The focus is illustrated in figure 6g. In other words, the receiver has the light created by the secondary sources forming the column of the matrix corresponding to the intensity distribution on the screen of figure 6c. Optical elements (4) can also be unified and produced by stamping or casting from relatively cheap polymeric optical transparent materials.

Thus, this paper shows the opportunity to transform existing approaches to the implementation of optical neural networks. The proposed approach allows to remove the problem of the inclusion the non-linear optical elements to the composition of the ANN since the signals generated by such network are directly fed to the nodes that execute commands. In other words, final elements are working as non-linear converter that performs certain functions. The approach also means using the neural networks with a small number of elements. The implementation of the optical neural networks can be carried out on the basis of the transformation of one-dimensional data array to two-dimensional one. It allows using the optical transparencies as the classical means of information processing for physical optics.

М. Н. Калимолдаев¹, И. Э. Сулейменов^{2,5}, И. Т. Пак¹,
Е. С. Витулёва², З. С. Тасбулатова², В. Н. Евстифеев², Г. А. Мун^{4,5}

¹Ақпараттық және есептеуіш технологиялар институты, Алматы, Қазақстан,

²Алматы энергетика және байланыс университеті, Алматы, Қазақстан,

⁴Әл-Фараби атындағы Қазақ ұлттық университеті, Алматы, Қазақстан

⁵Қазақстан Республикасы Инженерлік академиясы, Алматы, Қазақстан

ОПТИКАЛЫҚ НЕЙРОНДЫҚ ЖЕЛІЛЕРДІ ФИЗИКАЛЫҚ ІСКЕ АСЫРУ ТУРАЛЫ МӘСЕЛЕГЕ

Аннотация. Салыстырмалы түрде аздаған элементтерден тұратын оптикалық нейрондық желілерді практикалық пайдалану мүмкіндіктері қарастырылады. Мұндай оптикалық нейрондық желілер адаптивті оптика жүйесінде қолданылуы мүмкін. Бұл жағдайда нейрондық желіні пайдалану сипаты жүйенің сипаттамаларын өзгертуді қамтамасыз ететін әсерді қалыптастырады. Мұндай тәсілдемені қолдану мысалы – күннің кездейсоқ жылжуы кезінде параболалық шағылдырғышты автоматты түрде құруға арналған адаптивті оптикалық жүйе. Бұл міндетті шешу өзекті болып табылады, өйткені қазіргі уақытта гелиокондырғыларда қолданылатын параболалық шағылыстырғыштар қажетті экономикалық тиімділікті қамтамасыз етпейді. Адаптивті оптика жүйелерін пайдалану бұл проблеманы айналы жабыны бар жұқа полимерлі пленкадан жасалған жеңіл параболалық шағылыстырғыштарға өту есебінен шешуге мүмкіндік береді. Бұл жағдайда параболалық шағылдырғыштың нысанын бекіту атмосфералық қысымнан біршама асатын қысым кезінде газбен толтырылған баллон жүйесін пайдалану есебінен қамтамасыз етіледі. Параболалық шағылыстырғыштың салмағы шағын айналмалы нүктені дамытатын сервожетек элементтерін пайдалануға мүмкіндік береді. Атап айтқанда, бұл баллонды реттеуші элементтерді пайдалануға мүмкіндік береді, олардың көлемі олардағы газды күн жылуымен қыздыру кезінде өзгереді. Бұл жағдайда басқару әсері сервожетекті эле-

менттерде жүйеге түсетін күн энергиясының бөлігін фокустау есебінен жасалады. Жұмыста оптикалық нейрондық желілердің әртүрлі конструкциясының нұсқалары қарастырылады. Сонымен қатар, ең тиімді салмақ коэффициенттерінің матрицасы ретінде жұқа оптикалық транспарантты пайдаланатын оптикалық нейрондық желі болып табылатыны көрсетілді. Бұл жағдайда желінің бірінші қабатының нейрондарына жауап беретін бастапқы жарық көздерінің әрқайсысы бірнеше бейнелерді қалыптастырады, нәтижесінде желілік көптеген көздер екі өлшемді болып өзгереді. Бұл матрицаны бағандар бойынша оптикалық қосу аддитивті қосу операциясының орындалуын қамтамасыз етеді, ол екінші қабатты оптикалық нейрондардың жұмысын көрсетеді.

Түйін сөздер: нейрондық желі, оптикалық сигнал, баламалы энергетика, шағылыстырғыштар, басқару сигналдары.

**М. Н. Калимолдаев¹, И. Э. Сулейменов^{2,5}, И. Т. Пак¹,
Е. С. Витулѐва², З. С. Тасбулатова², В. Н. Евстифеев², Г. А. Мун^{4,5}**

¹Институт информационных и вычислительных технологий, Алматы, Казахстан,

²Алматинский университет энергетика и связи, Алматы, Казахстан,

⁴Казахский национальный университет им. аль-Фараби, Алматы, Казахстан,

⁵Национальная инженерная академия Республики Казахстан, Алматы, Казахстан

К ВОПРОСУ О ФИЗИЧЕСКОЙ РЕАЛИЗАЦИИ ОПТИЧЕСКИХ НЕЙРОННЫХ СЕТЕЙ

Аннотация. Рассматриваются возможности практического использования оптических нейронных сетей, содержащих сравнительно небольшое количество элементов. Показано, что оптические нейронные сети такого рода могут найти применение в системах адаптивной оптики. В этом случае характер использования нейронной сети предполагает, что она формирует воздействие, обеспечивающее изменение характеристик системы. Примером применения такого рода подхода является адаптивная оптическая система, предназначенная для автоматической подстройки параболического отражателя при перемещении солнца по небосклону. Решение данной задачи является актуальным, так как в настоящее время параболические отражатели, используемые в гелиоустановках, не обеспечивают нужной экономической эффективности. Использование систем адаптивной оптики позволяет решить данную проблему за счёт перехода к легким параболическим отражателям, выполненным из тонкой полимерной пленки с зеркальным покрытием. Фиксация формы параболического отражателя в данном случае обеспечивается за счёт использования баллонной системы, заполненной газом при давлении, несколько превышающим атмосферное. Малый вес параболического отражателя позволяет использовать сервоприводные элементы, развивающие небольшой вращательный момент. В частности, это позволяет использовать баллонные регулирующие элементы, объем которых изменяется при нагреве находящегося в них газа солнечным теплом. Управляющее воздействие в данном случае создается за счёт фокусировки части солнечной энергии, поступающей в систему на сервоприводных элементах. В работе рассматриваются варианты различной конструкции оптических нейронных сетей. Показано, что наиболее эффективным с точки зрения простоты реализации является оптическая нейронная сеть, использующая в качестве матрицы весовых коэффициентов тонкий оптический транспарант. В данном случае каждый из исходных источников света, отвечающих нейронам первого слоя сети, формирует несколько изображений, в результате чего линейное множество источников преобразуется в двумерное. Оптическое суммирование данной матрицы по столбцам обеспечивает выполнение операции аддитивного суммирования, которое задает работу оптических нейронов второго слоя.

Ключевые слова: нейронная сеть, оптический сигнал, альтернативная энергетика, отражатели, управляющие сигналы.

Information about authors:

Kalimoldayev Maksat, Doctor of Physical and Mathematical Sciences, Professor, General Director of Institute of Information and Computational Technologies of the MES RK, Academician, Vice President and Chief Scientific Secretary of the National Academy of Sciences of the Republic of Kazakhstan, Honored Scientist of the Republic of Kazakhstan, Institute of Information and Computational Technologies, Almaty, Kazakhstan; mnk@ipic.kz; <https://orcid.org/0000-0003-0025-8880>

Suleimenov Ibragim, Academician of the National Engineering Academy of the Republic of Kazakhstan, Doctor of Chemical Sciences, Candidate of Physical and Mathematical Sciences, Professor, Almaty University of Power Engineering and Telecommunications, Almaty, Kazakhstan; esenych@ya.ru; <https://orcid.org/0000-0002-7274-029X>

Pak Ivan, Doctor of Technical Sciences, Professor, Chief Researcher of the Institute of Information and Computational Technologies of the MES RK, Honored Worker of Science and Technology of the RK, Academician of the Russian Academy of Natural Sciences; pak.it@mail.ru; <https://orcid.org/0000-0003-4892-5996>

Vitulyova Elizaveta, PhD student, Almaty University of Power Engineering and Telecommunications, Almaty, Kazakhstan; lizavita@list.ru; <https://orcid.org/0000-0002-6075-4870>

Tasbulatova Zarina, PhD student, Almaty University of Energy and Telecommunications, Almaty, Kazakhstan; z.tasbulatova@gmail.com; <http://orcid.org/0000-0002-0993-1982>

Yevstifeyev Vladimir, MoS student, Almaty University of Power Engineering and Telecommunications, Almaty, Kazakhstan; yvladimir@gmail.com; <https://orcid.org/0000-0001-8335-2738>

Mun Grigory, Al-Farabi Kazakh National University, Almaty, Kazakhstan, Doctor of Chemical Sciences, Professor, Head of the Department of Chemistry and Technology of Organic Substances, Natural Compounds and Polymers of the Al-Farabi Kazakh National University, Academician of the National Engineering Academy of the Republic of Kazakhstan; mungrig@ya.ru; <https://orcid.org/0000-0001-5522-1255>

REFERENCES

- [1] Kalimoldayev M.N., Pak I.T., Baipakbayeva S.T., Mun G.A., Shaltykova D.B., Suleimenov I.E. (2018). Methodological basis for the development strategy of artificial intelligence systems in the republic of kazakhstan in the message of the president of the republic of kazakhstan dated october 5, 2018 // *News of NAS RK. Series of geology and technical sciences*. **2018**. Vol. 5, N 431. P. 47-54. <https://doi.org/10.32014/2018.2518-170X.34>. ISSN 2518-170X (Online). ISSN 2224-5278 (Print).
- [2] Sulejmenov I.Je., Mun G.A. Konceptsiya razvitiya molekularnoj informatiki kak sinteza fiziko-himii polimerov i informacionnyh tehnologij // *Izvestija nauchno-tehnicheskogo obshhestva «KAHAK»*. **2018**. N 1(60). P. 60-75 (in Rus.).
- [3] Suleimenov I., Panchenko S., Erdauletova M. Molekuljarnoe programmirovaniye: analogiya s radiotekhnicheskimi sistemami // *Izvestija NTO «KAHAK»*. **2015**. 4(51). P. 77-84. (in Rus.).
- [4] Mun G.A., Nurkeeva Z.S., Akhmetkalieva G.T., Shmakov S.N., Khutoryanskiy V.V., Lee S.C., Park K. Novel Temperature-Responsive Water-Soluble Copolymer based on 2-hydroxyethyl acrylate and Vinyl Butyl Ether and Their Interactions with Poly (acrylic acid) // *J. Polym. Sci.: Part B: Polym. Phys.* **2006**. Vol. 44. P. 195-204.
- [5] Mun G.A., Nurkeeva Z.S., Ermukhambetova B.B., Nam I.K., Kan V.A., Kudaibergenov S.E. Thermo- and pH-sensitive Amphiphilic Gels of Copolymers of Vinyl Ether of Ethylene Glycol // *Polym. Adv. Technol.* **1999**. Vol. 10, N 3. P. 151-156.
- [6] Milev M., Hristov M. Analog implementation of ANN with inherent quadratic nonlinearity of the synapses // *IEEE transactions on neural networks*. **2003**. Vol. 14, N 5. P. 1187-1200.
- [7] Aamer N., Ramachandran S. Hardware realization of neural network-based controller for autonomous robot navigation *Computing Methodologies and Communication (ICCMC)* // *International Conference on. IEEE*. **2017**. P. 243-248.
- [8] Abrol S., Mahajan R. Implementation of single artificial neuron using various activation functions and XOR Gate on FPGA chip *Advances in Computing and Communication Engineering (ICACCE)*, 2015 Second International Conference on // *IEEE*. **2015**. P. 118-123.
- [9] Pavlov A.V. Algebra Fur'e-dual'nyh operacij: logika s iskljucheniem // *Iskusstvennyj intellekt i prinjatije reshenij*. **2012**. N 3. P. 26-38 (in Rus.).
- [10] Pavlov A.V. Realizacija logiko-lingvisticheskikh modelej metodom Fur'e-golografii // *Izvestija Akademii Nauk. Teorija i sistemy upravlenija*. **2003**. 2. P. 118-125 (in Rus.).
- [11] Sathyamurthy R., El-Agouz S.A., Nagarajan P.K., Subramani J., Arunkumar T., Mageshbabu D., Prakash N.A. Review of integrating solar collectors to solar still Renewable // and Sustainable Energy Reviews. **2017**. N 77. P. 1069-1097.
- [12] Fernández-García A., Zarza E., Valenzuela L., Pérez M. Parabolic-trough solar collectors and their applications // *Renewable and Sustainable Energy Reviews*. **2010**. N 14(7). P. 1695-1721.
- [13] Sabiha M.A., Saidur R., Mekhilef S., Mahian O. Progress and latest developments of evacuated tube solar collectors // *Renewable and Sustainable Energy Reviews*. **2015**. N 51. P. 1038-1054.
- [14] Prasad G.C., Reddy K.S., Sundararajan T. Optimization of solar linear Fresnel reflector system with secondary concentrator for uniform flux distribution over absorber tube // *Solar Energy*. **2017**. N 150. P. 1-12.
- [15] Karp J.H., Tremblay E.J., Ford J.E. Planar micro-optic solar concentrator *Optics // Express*. **2010**. N 18(2). P. 1122-1133.
- [16] Lovegrove K., Burgess G., Pye J. A new 500 m² paraboloidal dish solar concentrator // *Solar Energy*. **2011**. N 85(4). P. 620-626.
- [17] Li H., Huang W., Huang F., Hu P., Chen Z. Optical analysis and optimization of parabolic dish solar concentrator with a cavity receiver // *Solar energy*. **2013**. N 92. P. 288-297.
- [18] Lee K., Lee J., Mazor B.A., Forrest S.R. Epitaxial lift-off processed GaAs thin-film solar cells integrated with low-cost plastic mini-compound parabolic concentrators // *In Photovoltaic Specialist Conference (PVSC)*, 2014 IEEE. **2014**. N 40. P. 2127-2129.
- [19] Abbasova T.S. Sistema navedeniya koncentratora na solnce // *Mir transporta*. **2016**. N 3. P. 44-53 (in Rus.).
- [20] Saljamov O.M., Gadzhiganov I.A., Mamedov F.F., Samedova U.F., Isakov G.I. Sistema avtomaticheskogo navedeniya gelioustanovok s parabolicheskimi i parabolocilindricheskimi koncentratorami na Solnce // *Al'ternativnaja jenergetika i jekologija*. **2007**. N 5. P. 44-53 (in Rus.).

**Publication Ethics and Publication Malpractice
in the journals of the National Academy of Sciences of the Republic of Kazakhstan**

For information on Ethics in publishing and Ethical guidelines for journal publication see <http://www.elsevier.com/publishingethics> and <http://www.elsevier.com/journal-authors/ethics>.

Submission of an article to the National Academy of Sciences of the Republic of Kazakhstan implies that the described work has not been published previously (except in the form of an abstract or as part of a published lecture or academic thesis or as an electronic preprint, see <http://www.elsevier.com/postingpolicy>), that it is not under consideration for publication elsewhere, that its publication is approved by all authors and tacitly or explicitly by the responsible authorities where the work was carried out, and that, if accepted, it will not be published elsewhere in the same form, in English or in any other language, including electronically without the written consent of the copyright-holder. In particular, translations into English of papers already published in another language are not accepted.

No other forms of scientific misconduct are allowed, such as plagiarism, falsification, fraudulent data, incorrect interpretation of other works, incorrect citations, etc. The National Academy of Sciences of the Republic of Kazakhstan follows the Code of Conduct of the Committee on Publication Ethics (COPE), and follows the COPE Flowcharts for Resolving Cases of Suspected Misconduct (http://publicationethics.org/files/u2/New_Code.pdf). To verify originality, your article may be checked by the Cross Check originality detection service <http://www.elsevier.com/editors/plagdetect>.

The authors are obliged to participate in peer review process and be ready to provide corrections, clarifications, retractions and apologies when needed. All authors of a paper should have significantly contributed to the research.

The reviewers should provide objective judgments and should point out relevant published works which are not yet cited. Reviewed articles should be treated confidentially. The reviewers will be chosen in such a way that there is no conflict of interests with respect to the research, the authors and/or the research funders.

The editors have complete responsibility and authority to reject or accept a paper, and they will only accept a paper when reasonably certain. They will preserve anonymity of reviewers and promote publication of corrections, clarifications, retractions and apologies when needed. The acceptance of a paper automatically implies the copyright transfer to the National Academy of Sciences of the Republic of Kazakhstan.

The Editorial Board of the National Academy of Sciences of the Republic of Kazakhstan will monitor and safeguard publishing ethics.

Правила оформления статьи для публикации в журнале смотреть на сайте:

www.nauka-nanrk.kz

ISSN 2518-170X (Online), ISSN 2224-5278 (Print)

<http://www.geolog-technical.kz/index.php/en/>

Верстка Д. Н. Калкабековой

Подписано в печать 12.04.2019.

Формат 70x881/8. Бумага офсетная. Печать – ризограф.
15,2 п.л. Тираж 300. Заказ 2.