

ISSN 2518-170X (Online),
ISSN 2224-5278 (Print)

ҚАЗАҚСТАН РЕСПУБЛИКАСЫ
ҰЛТТЫҚ ҒЫЛЫМ АКАДЕМИЯСЫНЫҢ
Қ. И. Сәтпаев атындағы Қазақ ұлттық техникалық зерттеу университеті

Х А Б А Р Л А Р Ы

ИЗВЕСТИЯ

НАЦИОНАЛЬНОЙ АКАДЕМИИ НАУК
РЕСПУБЛИКИ КАЗАХСТАН
Казакский национальный исследовательский
технический университет им. К. И. Сатпаева

NEWS

OF THE ACADEMY OF SCIENCES
OF THE REPUBLIC OF KAZAKHSTAN
Kazakh national research technical university
named after K. I. Satpayev

ГЕОЛОГИЯ ЖӘНЕ ТЕХНИКАЛЫҚ ҒЫЛЫМДАР СЕРИЯСЫ



СЕРИЯ ГЕОЛОГИИ И ТЕХНИЧЕСКИХ НАУК



SERIES OF GEOLOGY AND TECHNICAL SCIENCES

3 (429)

МАМЫР – МАУСЫМ 2018 ж.
МАЙ – ИЮНЬ 2018 г.
MAY – JUNE 2018

ЖУРНАЛ 1940 ЖЫЛДАН ШЫҒА БАСТАҒАН
ЖУРНАЛ ИЗДАЕТСЯ С 1940 г.
THE JOURNAL WAS FOUNDED IN 1940.

ЖЫЛЫНА 6 РЕТ ШЫҒАДЫ
ВЫХОДИТ 6 РАЗ В ГОД
PUBLISHED 6 TIMES A YEAR

NAS RK is pleased to announce that News of NAS RK. Series of geology and technical sciences scientific journal has been accepted for indexing in the Emerging Sources Citation Index, a new edition of Web of Science. Content in this index is under consideration by Clarivate Analytics to be accepted in the Science Citation Index Expanded, the Social Sciences Citation Index, and the Arts & Humanities Citation Index. The quality and depth of content Web of Science offers to researchers, authors, publishers, and institutions sets it apart from other research databases. The inclusion of News of NAS RK. Series of geology and technical sciences in the Emerging Sources Citation Index demonstrates our dedication to providing the most relevant and influential content of geology and engineering sciences to our community.

Қазақстан Республикасы Ұлттық ғылым академиясы "ҚР ҰҒА Хабарлары. Геология және техникалық ғылымдар сериясы" ғылыми журналының Web of Science-тің жаңаланған нұсқасы Emerging Sources Citation Index-те индекстелуге қабылданғанын хабарлайды. Бұл индекстелу барысында Clarivate Analytics компаниясы журналды одан әрі the Science Citation Index Expanded, the Social Sciences Citation Index және the Arts & Humanities Citation Index-ке қабылдау мәселесін қарастыруда. Web of Science зерттеушілер, авторлар, баспашылар мен мекемелерге контент тереңдігі мен сапасын ұсынады. ҚР ҰҒА Хабарлары. Геология және техникалық ғылымдар сериясы Emerging Sources Citation Index-ке енуі біздің қоғамдастық үшін ең өзекті және беделді геология және техникалық ғылымдар бойынша контентке адалдығымызды білдіреді.

НАН РК сообщает, что научный журнал «Известия НАН РК. Серия геологии и технических наук» был принят для индексирования в Emerging Sources Citation Index, обновленной версии Web of Science. Содержание в этом индексировании находится в стадии рассмотрения компанией Clarivate Analytics для дальнейшего принятия журнала в the Science Citation Index Expanded, the Social Sciences Citation Index и the Arts & Humanities Citation Index. Web of Science предлагает качество и глубину контента для исследователей, авторов, издателей и учреждений. Включение Известия НАН РК. Серия геологии и технических наук в Emerging Sources Citation Index демонстрирует нашу приверженность к наиболее актуальному и влиятельному контенту по геологии и техническим наукам для нашего сообщества.

Б а с р е д а к т о р ы
э. ғ. д., профессор, ҚР ҰҒА академигі

И.К. Бейсембетов

Бас редакторының орынбасары

Жолтаев Г.Ж. проф., геол.-мин. ғ. докторы

Р е д а к ц и я а л қ а с ы:

Абаканов Т.Д. проф. (Қазақстан)
Абишева З.С. проф., академик (Қазақстан)
Агабеков В.Е. академик (Беларусь)
Алиев Т. проф., академик (Әзірбайжан)
Бакиров А.Б. проф., (Қырғыстан)
Беспаев Х.А. проф. (Қазақстан)
Бишимбаев В.К. проф., академик (Қазақстан)
Буктуков Н.С. проф., академик (Қазақстан)
Булат А.Ф. проф., академик (Украина)
Ганиев И.Н. проф., академик (Тәжікстан)
Грэвис Р.М. проф. (АҚШ)
Ерғалиев Г.К. проф., академик (Қазақстан)
Жуков Н.М. проф. (Қазақстан)
Кенжалиев Б.К. проф. (Қазақстан)
Қожахметов С.М. проф., академик (Қазақстан)
Конторович А.Э. проф., академик (Ресей)
Курскеев А.К. проф., академик (Қазақстан)
Курчавов А.М. проф., (Ресей)
Медеу А.Р. проф., академик (Қазақстан)
Мұхамеджанов М.А. проф., корр.-мүшесі (Қазақстан)
Нигматова С.А. проф. (Қазақстан)
Оздоев С.М. проф., академик (Қазақстан)
Постолатий В. проф., академик (Молдова)
Ракишев Б.Р. проф., академик (Қазақстан)
Сейтов Н.С. проф., корр.-мүшесі (Қазақстан)
Сейтмуратова Э.Ю. проф., корр.-мүшесі (Қазақстан)
Степанец В.Г. проф., (Германия)
Хамфери Дж.Д. проф. (АҚШ)
Штейнер М. проф. (Германия)

«ҚР ҰҒА Хабарлары. Геология мен техникалық ғылымдар сериясы».

ISSN 2518-170X (Online),

ISSN 2224-5278 (Print)

Меншіктенуші: «Қазақстан Республикасының Ұлттық ғылым академиясы» РҚБ (Алматы қ.).

Қазақстан республикасының Мәдениет пен ақпарат министрлігінің Ақпарат және мұрағат комитетінде
30.04.2010 ж. берілген №10892-Ж мерзімдік басылым тіркеуіне қойылу туралы куәлік.

Мерзімділігі: жылына 6 рет.

Тиражы: 300 дана.

Редакцияның мекенжайы: 050010, Алматы қ., Шевченко көш., 28, 219 бөл., 220, тел.: 272-13-19, 272-13-18,
<http://nauka-nanrk.kz/geology-technical.kz>

© Қазақстан Республикасының Ұлттық ғылым академиясы, 2018

Редакцияның Қазақстан, 050010, Алматы қ., Қабанбай батыра көш., 69а.

мекенжайы: Қ. И. Сәтбаев атындағы геология ғылымдар институты, 334 бөлме. Тел.: 291-59-38.

Типографияның мекенжайы: «Аруна» ЖК, Алматы қ., Муратбаева көш., 75.

Г л а в н ы й р е д а к т о р
д. э. н., профессор, академик НАН РК

И. К. Бейсембетов

Заместитель главного редактора

Жолтаев Г.Ж. проф., доктор геол.-мин. наук

Р е д а к ц и о н н а я к о л л е г и я:

Абаканов Т.Д. проф. (Казахстан)
Абишева З.С. проф., академик (Казахстан)
Агабеков В.Е. академик (Беларусь)
Алиев Т. проф., академик (Азербайджан)
Бакиров А.Б. проф., (Кыргызстан)
Беспаяев Х.А. проф. (Казахстан)
Бишимбаев В.К. проф., академик (Казахстан)
Буктуков Н.С. проф., академик (Казахстан)
Булат А.Ф. проф., академик (Украина)
Ганиев И.Н. проф., академик (Таджикистан)
Грэвис Р.М. проф. (США)
Ергалиев Г.К. проф., академик (Казахстан)
Жуков Н.М. проф. (Казахстан)
Кенжалиев Б.К. проф. (Казахстан)
Кожаметов С.М. проф., академик (Казахстан)
Конторович А.Э. проф., академик (Россия)
Курскеев А.К. проф., академик (Казахстан)
Курчавов А.М. проф., (Россия)
Медеу А.Р. проф., академик (Казахстан)
Мухамеджанов М.А. проф., чл.-корр. (Казахстан)
Нигматова С.А. проф. (Казахстан)
Оздоев С.М. проф., академик (Казахстан)
Постолатий В. проф., академик (Молдова)
Ракишев Б.Р. проф., академик (Казахстан)
Сейтов Н.С. проф., чл.-корр. (Казахстан)
Сейтмуратова Э.Ю. проф., чл.-корр. (Казахстан)
Степанец В.Г. проф., (Германия)
Хамфери Дж.Д. проф. (США)
Штейнер М. проф. (Германия)

«Известия НАН РК. Серия геологии и технических наук».

ISSN 2518-170X (Online),

ISSN 2224-5278 (Print)

Собственник: Республиканское общественное объединение «Национальная академия наук Республики Казахстан (г. Алматы)

Свидетельство о постановке на учет периодического печатного издания в Комитете информации и архивов Министерства культуры и информации Республики Казахстан №10892-Ж, выданное 30.04.2010 г.

Периодичность: 6 раз в год

Тираж: 300 экземпляров

Адрес редакции: 050010, г. Алматы, ул. Шевченко, 28, ком. 219, 220, тел.: 272-13-19, 272-13-18,
<http://nauka-nanrk.kz/geology-technical.kz>

© Национальная академия наук Республики Казахстан, 2018

Адрес редакции: Казахстан, 050010, г. Алматы, ул. Кабанбай батыра, 69а.

Институт геологических наук им. К. И. Сатпаева, комната 334. Тел.: 291-59-38.

Адрес типографии: ИП «Аруна», г. Алматы, ул. Муратбаева, 75

E d i t o r i n c h i e f

doctor of Economics, professor, academician of NAS RK

I. K. Beisembetov

Deputy editor in chief

Zholtayev G.Zh. prof., dr. geol-min. sc.

E d i t o r i a l b o a r d :

Abakanov T.D. prof. (Kazakhstan)
Abisheva Z.S. prof., academician (Kazakhstan)
Agabekov V.Ye. academician (Belarus)
Aliyev T. prof., academician (Azerbaijan)
Bakirov A.B. prof., (Kyrgyzstan)
Bespayev Kh.A. prof. (Kazakhstan)
Bishimbayev V.K. prof., academician (Kazakhstan)
Buktukov N.S. prof., academician (Kazakhstan)
Bulat A.F. prof., academician (Ukraine)
Ganiyev I.N. prof., academician (Tadjikistan)
Gravis R.M. prof. (USA)
Yergaliev G.K. prof., academician (Kazakhstan)
Zhukov N.M. prof. (Kazakhstan)
Kenzhaliyev B.K. prof. (Kazakhstan)
Kozhakhmetov S.M. prof., academician (Kazakhstan)
Kontorovich A.Ye. prof., academician (Russia)
Kurskeyev A.K. prof., academician (Kazakhstan)
Kurchavov A.M. prof., (Russia)
Medeu A.R. prof., academician (Kazakhstan)
Muhamedzhanov M.A. prof., corr. member. (Kazakhstan)
Nigmatova S.A. prof. (Kazakhstan)
Ozdoev S.M. prof., academician (Kazakhstan)
Postolatii V. prof., academician (Moldova)
Rakishev B.R. prof., academician (Kazakhstan)
Seitov N.S. prof., corr. member. (Kazakhstan)
Seitmuratova Ye.U. prof., corr. member. (Kazakhstan)
Stepanets V.G. prof., (Germany)
Humphery G.D. prof. (USA)
Steiner M. prof. (Germany)

News of the National Academy of Sciences of the Republic of Kazakhstan. Series of geology and technology sciences.

ISSN 2518-170X (Online),

ISSN 2224-5278 (Print)

Owner: RPA "National Academy of Sciences of the Republic of Kazakhstan" (Almaty)

The certificate of registration of a periodic printed publication in the Committee of information and archives of the Ministry of culture and information of the Republic of Kazakhstan N 10892-Ж, issued 30.04.2010

Periodicity: 6 times a year

Circulation: 300 copies

Editorial address: 28, Shevchenko str., of. 219, 220, Almaty, 050010, tel. 272-13-19, 272-13-18,
<http://nauka-nanrk.kz/geology-technical.kz>

© National Academy of Sciences of the Republic of Kazakhstan, 2018

Editorial address: Institute of Geological Sciences named after K.I. Satpayev
69a, Kabanbai batyr str., of. 334, Almaty, 050010, Kazakhstan, tel.: 291-59-38.

Address of printing house: ST "Aruna", 75, Muratbayev str, Almaty

NEWS

OF THE NATIONAL ACADEMY OF SCIENCES OF THE REPUBLIC OF KAZAKHSTAN

SERIES OF GEOLOGY AND TECHNICAL SCIENCES

ISSN 2224-5278

Volume 3, Number 429 (2018), 197 – 207

UDC 539.3.6:621.01.03

Code of MRNTI 30.19.51

**M. A. Sakimov¹, A. K. Ozhikenova², B. M. Abdeyev¹,
M. V. Dudkin¹, A. K. Ozhiken², S. Azamatkyzy¹**

¹East Kazakhstan state technical university named after D. Serikbayev, Ust-Kamenogorsk, Kazakhstan,

²Kazakh National University named after al-Farabi, Almaty, Kazakhstan.

E-mail: msakimov@mail.ru, aiman84@mail.ru, m.abdeyeva@mail.ru,
doudkin@mail.ru, ozhiken11@gmail.com, asamal-0107@mail.ru

FINDING ALLOWABLE DEFORMATION OF THE ROAD ROLLER SHELL WITH VARIABLE CURVATURE

Abstract. The article examines a new mechanic and mathematical model for the conditions of the roller flexible shell of the road roller assessing its load bearing capacity, reliability and strength and making it possible, depending on the properties of the material to be compacted, to select abroad roller with the required performance of rollers before the work is started. It also reviews issues related to the acceptable transformation of the flexible shell circular surface and allowable displacement limit while exceeding of the latter may lead to a failure of the road roller capability. The article is aimed at giving scientific evidence and finding feasibility of using flexible shells in the road roller design and determining their parameters that are sufficiently accurate to be used for engineering purposes. It also describes the experimental equipment used to investigate the parameters of flexible shells and presents practical effect in the form of schematics and full-scale structures, as well as an experimental roller of a road roller with a flexible steel shell. The results complement and integrate into previous studies and they are compared with analytical and elemental solutions of similar tasks from the scientific literature [7, 9, 13, 14].

Key words: Cylindrical shells, Elastic Deformation, elastic bending of a circular ring, flexible shell of roller of road roller, load bearing capacity, strength, kinematic parameters.

1. Introduction. Compulsory compaction of soil, crushed stone and asphalt in the road sector is actually the main operation to ensure their strength, stability and durability [6].

The main compacting equipment is a road roller which can be equipped with rollers of various shapes and dimensions.

Analysis of the available experimental data shows that the increase in the roller weight without adjustments in the roller diameter does not make it possible for the standard roller to adapt to the current properties of the compacted material because the pressure applied to the contact area may exceed the material strength and this will lead to over-compaction and loosening of the material.

To remedy the situation and adapt to the properties of the compacted material using its optimum and compaction-friendly parameters is possible only by the application of road rollers with flexible rollers [1-3] which, given permanent static weight of the roller, allow for changing its linear pressure on the material in the area of their contact by varying the curvature radius of the roller.

The radius of flexible rollers is changed by their forced deformation along the entire perimeter and local deformation in the area of contact with the ground [1, 4, 5].

The economic significance of the problem is so high that even its partial solution will have a noticeable effect on the efficiency of road construction and their operation reliability [8, 10, 12].

2. Problem. Modern compaction equipment is marked by more advanced technologies and compaction effect that provides a change in the pressure at the supporting surface contact area due to variation in the shell curvature radius. However, given the roller weight and its pressure on the shell, an

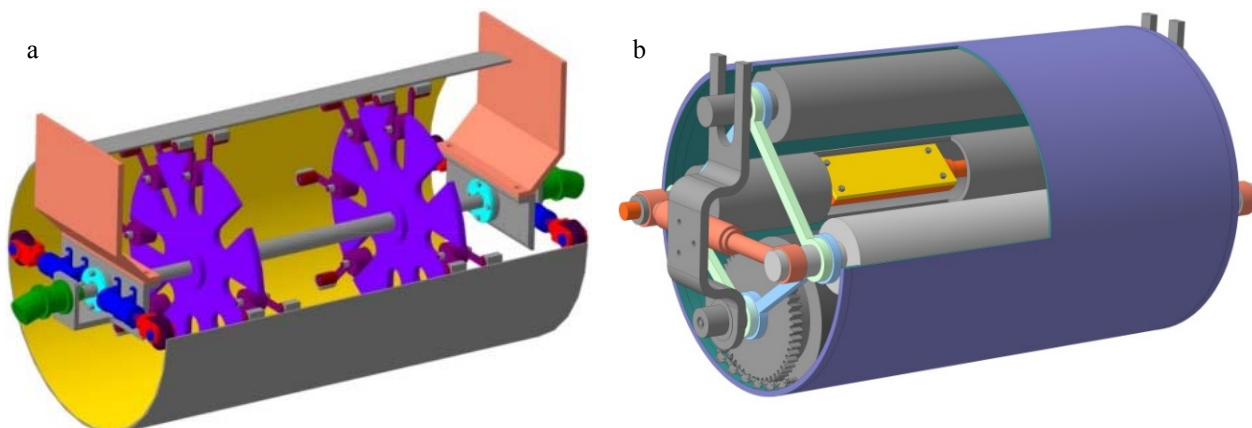

Figure 1 – Rollers of road rollers with flexible shells under provisional patents of Kazakhstan No. 18131 (a) and No. 21592 (b)

issue of the flexible shell operability, reliability and ability to recover its original shape becomes highly relevant [6].

Cylindrical shells with different thickness and made of different materials behave differently when forcibly deformed by external or internal forces. After the cylindrical shape is changed in order to achieve the desired contact area, if the allowable deformation limit is exceeded, the steel roller shell may not recover its original shape and remain flattened or stretched. Then the capability of the roller or the road roller as a whole will be completely broken, limited or terminated.

It is required to conduct a research and find scientific evidence of the allowable vertical and horizontal displacements of the roller shell after which the shell will guaranteedly retain its initial cylindrical shape. It is also needed to complete the previous studies of the roller flexible shell [6], combining them with the findings of experimental test of its stress and strain state.

3. Analytical Model. The goal of this research is to do an experimental test, complement and complete earlier analytical linear connection of displacement u, v [6] for a scale-down model of a cylindrical shell made of engineering alloy steel 30XГСА (GOST 4543-71) with modulus of elasticity $E=2,11 \cdot 10^5$ MPa (N/mm²), Poisson's ratio $\mu=0,282$, yield limit $\sigma_T=830$ MPa (N/mm²) and dimensions $R=152,15$ mm; $B=399,3$ mm; $\delta=1,98$ mm - outside radius, width and thickness respectively, (figure 1) frequently used for various operating elements of road and screening equipment [6-8, 15, 16].

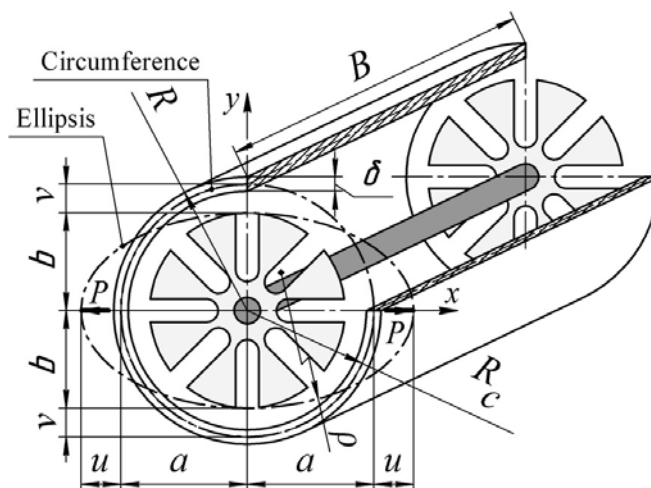

Figure 2 – Theoretical and calculation schematics of cylindrical shell

Let us integrate the analytical model of the roller stress and strain state presented earlier [6] and the new calculated and force linear connections:

For the ellipsis curvature radius $\rho = \rho(x)$ (figure 2), upon replacing arbitrary size of bodies a, b with

their allowable values a_n , b_n , the function $\rho_n = \rho_n(x)$ was obtained [6] at the highest change of the deformed shell contour expressed in terms of R_c :

$$\rho_n = \rho_n(x) = 1,333R_c \left(1 - 0,2708 \frac{x^2}{R_c^2}\right)^{3/2}, -a_n \leq x \leq a_n \quad (1)$$

where, when $x=0$,

$$\rho_{max} = \rho_n(0) = 1,333R_c, \quad (2)$$

and when $x = \pm a_n = \pm 1,09537$

$$\rho_{min} = \rho_n(\pm a_n) = 0,7394R_c. \quad (3)$$

Functional width of flexible shell δ , should fall into the ranges

$$\delta \leq \delta_{max} = 2,18 \text{ cm} \quad (4)$$

When this condition is fulfilled (4), the given physical and mathematical model will be sufficiently correct with an error value allowable for engineering calculation below 5% [12, 14].

The function of internal [6] bending moment $M=M(x)$:

$$\frac{M}{H} = \frac{1}{\rho} - \frac{1}{R_c} \quad (5)$$

where H is rigidity of the shell rectangular section core [8]:

$$H = \frac{EB\delta^3}{12(1-\mu^2)} \quad (6)$$



Figure 3 – Test stand for finding allowable displacement of flexible shell and its instruments

The rule of the moment sign M is derived from equation (5), meaning that the parameter $H > 0$: if the core curvature increases, then $M > 0$ and $M < 0$ – if it decreases. The difference change sign is also considered $1/\rho - 1/R_c$, i.e. the positive value $M > 0$ corresponds to $1/\rho - 1/R_c > 0$ and vice versa.

Changing the symbols $M \Rightarrow M_n$, $\rho \Rightarrow \rho_n$ and substituting ρ_n , based on (1), in the ratio (5), let us obtain a linear connection for the function of the ultimate bending moment $M_n(x)$:

$$M_n = M_n(x) = \frac{H}{R_c} \left[\frac{0,7502}{\left(1 - 0,2708 \frac{x^2}{R_c^2}\right)^{3/2}} - 1 \right] \quad (7)$$

$$-1,09537R_c \leq x \leq 1,09537R_c.$$

Figure 4 shows dimensionless modification M_n^* of epure M_n

$$M_n^* = M_n \frac{R_c}{H} = \frac{0,7502}{\left(1 - 0,2708 \frac{x^2}{R_c^2}\right)^{3/2}} - 1 \quad (8)$$

That corresponds to analytic expression (7) subject to the symmetry of the figure 4 calculation model while to calculate the boundary coordinate y_n of the ellipsis (M_n^* epure basis) the formulay $= \pm b \sqrt{1 - \frac{x^2}{a^2}}$ was used where $a = a_n$ and $b = b_n$, that means

$$y_n = \pm 0,9R_c \sqrt{1 - \frac{x^2}{a_n^2}} \quad (9)$$

where the variablexis changed though the interval $\pm 0,2 a_n$:

$$x = 0; \pm 0,2 a_n; \pm 0,4 a_n; \pm 0,6 a_n; \pm 0,8 a_n; \pm a_n \quad (10)$$

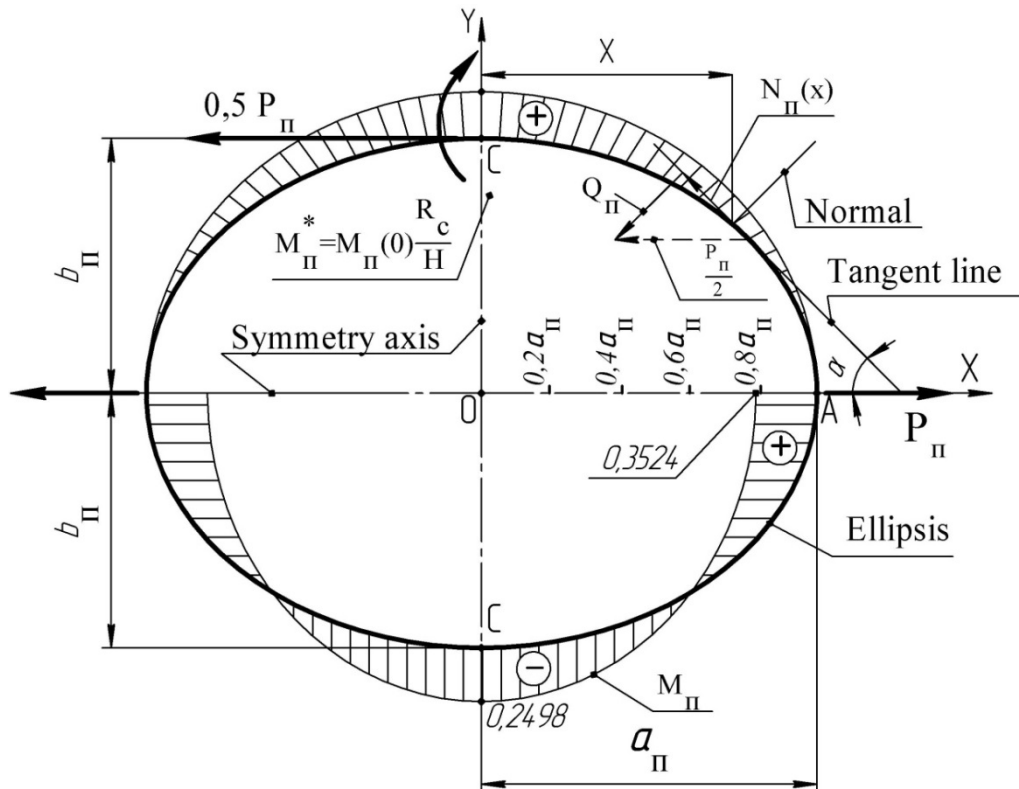

Figure 4 – E pures of internal force factor M_{II}^* and N_{II} adequate to the limiting boundary condition of rigidity $v_n = 0,1 \cdot R_c$ [6]

The figures $M_{II}^* = M_{II}^*(x)$ are defined for the same points (10) of elliptical profile and given in table 1.

Table 1 – E pure M_n^* calculation values for the ultimate bending moment

x	0	0,2 a_n	0,4 a_n	0,6 a_n	0,8 a_n	a_n
y_n	$\pm 0,9R_c$	$\pm 0,882R_c$	$\pm 0,825R_c$	$\pm 0,72R_c$	$\pm 0,54R_c$	0
M_n^*	-0,2498	-0,2372	-0,1890	-0,0416	0,1263	0,3524

Using figure 4 let us find the function of axial force $N_n = N_n(x)$ in the shell cross section

$$N_n = \frac{P_n}{2} \cos \alpha \quad (11)$$

where $\alpha = \alpha(x)$ is an angle of descent to the ellipsis changing in quadrant I at a closed interval

$$0 \leq \alpha \leq \frac{\pi}{2} \quad (12)$$

and dependent on the argument x based on known differential and trigonometric ratio [7] subject to (1.37):

$$tg \alpha = \frac{dy_n}{dx} = - \frac{0,9R_c x}{a_n^2 \sqrt{1 - \frac{x^2}{a_n^2}}} \quad (13)$$

$$\cos \alpha = \frac{1}{\sqrt{1 + tg^2 \alpha}} = \frac{1}{\sqrt{1 + \frac{dy_n^2}{dx^2}}} \quad (14)$$

The general form of half of the epure $N_n = N_n(x)$ is shown in the same figure 4 and $N_{max} = N_n(0) = \frac{P}{2}$, when $x = 0$ and $N_{min} = N_n(a_n) = 0$ section A.

In accordance with the epure M_n^* (figure 4) and linear connections (6), (8), the bending moment M_n in the point A at $x = \pm a_n = \pm 1,09537R_c$ equals to

$$M_n = M_n(\pm a_n) = 0,3524 \frac{H}{R_c} = 0,05873 \frac{EB\delta^2}{(1-\mu^2)(2R-\delta)} \quad (15)$$

When finding $M_n(\pm a_n)$ by the static method [16-18] as the moments of all forces summed with respect to the point A for the upper ($\sum m_A^{upper}$) right quarter of the ring, let us obtain:

$$\begin{aligned} M_n(\pm a_n) &= \sum m_A^{upper} = \frac{P_n}{2} \cdot b_n - M_n(0) = 0,45P_n R_c + 0,2498 \frac{H}{R_c} = \\ &= 0,225P_n(2R - \delta) + 0,04163 \frac{EB\delta^2}{(1-\mu^2)(2R-\delta)}; \end{aligned} \quad (16)$$

where $M_n(0)$ is a bending moment in the section C calculated similarly to (15) at $x=0$, i.e.

$$M_n(0) = -0,2498 \frac{H}{R_c} = -0,04163 \frac{EB\delta^3}{(1-\mu^2)(2R-\delta)}. \quad (17)$$

By making right part of the equations (16) equal to that of (17)

$$M_n(\pm a_n) = \sum m_A^{upper}, \quad (18)$$

let us find the unknown stretching force, maximum permissible by boundary condition of rigidity P_n :

$$P_n = \frac{0,076 \cdot EB\delta^3}{(1-\mu^2)(2R-\delta)^2}. \quad (19)$$

It is obvious that the equation (18) and the adequate load P_n determined by the above ratio (19) ensure an ellipsis-like bending of the shell. This operation and process requirement is taken into account when manufacturing flexible rollers (figure 5) of a road roller based on known inventions [4, 5] and it belongs to the basic preconditions of the calculated theoretical model.



Figure 5 – Road roller with flexible shell, Kazakhstan patent No. 18131

The essential feature of the task set in this research relates to two types of non-linearity available: geometrical linearity resulted from large displacements u, v ($u \gg \delta; v \gg \delta$) that vastly exceeds the thickness δ of the roller cylindrical shell with an original radius of midsurface $R_c = const$, and a constructive one resulted from a supposition about elastic bending of a circular ring [6, 7] by two mutually balanced radially stretching concentrated forces P by ellipsis equation with semi-axes a, b in the coordinate system xOy (figure 2) given the following correlations between the design values are maintained:

$$\delta \ll B, \frac{\delta}{\rho_{min}} \leq \frac{1}{20}; \quad (20)$$

where ρ_{min} is the lowest median radius of the shell curvature in case of an elliptical shape:

$$\rho_{min} = b^2 \cdot a^{-1} \leq R_c, \quad (21)$$

As for the assumption about the transformation of the roller circular surface to an elliptical one that relates to flexible type, a possibility of its existence is proved at any value of stretching force P as long as the shell is a physically linear structure [8], while the length of the arc S of the deformed cylinder guide is not changed when it recovers to the circumference with a radius R_c , i.e. according to the classical assumption used in the fundamental theory for calculation of flexible elastic rods: $S = 2\pi R_c = const$.

Then let us approximate the perimeter length S by a complete elliptical integral $E\left(\frac{\pi}{2}, \xi\right) \equiv E(\xi)$ of the second sort in the form of Legendre which is reported not to be expressed through elementary functions. Reference tables [8] were compiled for its calculation depending on eccentricity or ellipsis module ξ with a large semi-axis $a \geq b$. For circumference ($a=b=R_c$) which is a special case of the equation (2), the parameter $\xi=0$, and $E(0)=1,5708$ [8].

$$S = 4a \cdot E(\xi), \quad (22)$$

$$\xi = \sqrt{1 - \frac{b^2}{a^2}}, 0 \leq \xi < 1 \quad (23)$$

The further mathematical modeling of the deformed state of the shell (figure 2) is based on a functional equation $P = P(\xi)$ adequate to a design model of pure bending [8] and the following classic preconditions [4, 6, 7, 8, 11] along with the limitations (20), (22):

– the material of the structure with an elasticity module E and Poisson's ratio μ is a homogeneous, isotropic, continuous material governed by Hooke's law while the proper mass of the shell is not taken into account.

– by the ratio of geometric characteristics $\rho_{min} \gg 5\delta$, that satisfies a boundary in equation (3), the ring element of figure 2 is classified as a thin beam – cover ($B \gg 5\delta$) of low curvature with all known simplifications that arise there [11];

– classic Kirchhoff and Love's hypotheses regarding invariability of normal to the deformed middle surface of the shell and the lack of pressure from one material layer to another are complied with.

A theoretical linear connection $P(\xi)$ obtained by the method [2] corresponding to the above assumptions takes the form of

$$P = P(\xi) = \frac{EB\delta^3}{6(1-\mu^2)R_c^2} \left(1 + \frac{a^3}{b^3} - \frac{2a}{R_c b} \right) = \frac{8EB\delta^3 E(\xi)}{3\pi^2(1-\mu^2)(2R-\delta)^2} \left\{ \frac{E(\xi) \left[(1-\xi^2)\sqrt{1-\xi^2} + 1 \right] - \pi(1-\xi^2)}{(1-\xi^2)\sqrt{1-\xi^2}} \right\} \quad (24)$$

and the ellipsis semi-axes are described by the expressions:

$$a = a(\xi) = \frac{\pi R_c}{2E(\xi)}, \quad b = b(\xi) = \frac{\pi\sqrt{1-\xi^2}}{2E(\xi)} \cdot R_c \quad (25)$$

Guided by (5)-(7), at the medium radius (figure-2)

$$R_c = R - \frac{\delta}{2} = 152,15 - \frac{1,98}{2} = 151,16 \text{ mm.} \quad (26)$$

Governed by design and process considerations [1, 21] let us introduce the rigidity condition (figure 2) $v \leq 0,1R_c$ into the calculation model and from the transcendental equation [2]

$$E(\xi_n) = \frac{\pi\sqrt{1-\xi_n^2}}{1,8} \quad (27)$$

let us find the limitary eccentricity $\xi_n = 0,57$ at $\pi = 3,1416$, and the respective boundary values $a_n = 1,0954R_c$, $b_n = 0,9 \cdot R_c$, $u_n = 0,0954R_c$, $v_n = 0,1R_c$ of the functions (25) of ellipsis semi-axes and displacements where the variable ξ ranges within $0 \leq \xi \leq \xi_n = 0,57$.

$$u = u(\xi) = \left[\frac{\pi}{2 \cdot E(\xi)} - 1 \right] \cdot R_c, \quad v = v(\xi) = \left[1 - \frac{\pi\sqrt{1-\xi^2}}{2 \cdot E(\xi)} \right] \cdot R_c \quad (28)$$

Replacing arbitrary sizes of semi-axes a, b with their allowable values a_n, b_n – (14) in (21) let us obtain [2] $\rho_{min}^{(n)} = 0,7394 R_c$. Then the second boundary in equation (20) becomes more explicit

$$\delta \ll 0,05\rho_{min}^{(n)} = 0,03697 R_c. \quad (29)$$

For example, at $R_c = 151,16 \text{ mm}$ the given thickness $\delta = 1,98 \text{ mm}$ of the studied structure (figure 2) based on (29) meets the necessary condition [2] $\delta = 1,98 \text{ mm} < \delta_{max} = 5,52 \text{ mm}$ by a wide margin. This ensures a sufficient correctness and accuracy of the physical and mathematical model with an error value allowable for engineering calculation below 5% [7, 19, 20].

4. Experimental Procedure and Results. To verify the theoretical inferences and find the experimental displacement $u_s = u_s(P)$, $v_s = v_s(P)$ a special stand was designed in compliance with the applicable process requirements to experimental research on materials and structures [12, 17, 18]. The facility includes three dial gauges – an IC detector (GOST 577-68) for measuring linear displacement between

0 and 10 mm with an accuracy of 0,01 mm; and force measuring instrument - an indicator-type dynamometer DORM 0,1 (GOST 9530-60) with New tone scale (N), unit value of 1,724N.

The flexible shell for uniform distribution of the force P along the width B was fixed along its axis between the rigid cylindrical stops, movable - 5 and fixed - 8, connected with the drive and instruments. All kinematic changes in the shape of the roller flexible shell model that occur when the movable stop starts moving as the result of the tension at the rod moved by the rotating adjusting nut were recorded by the instruments and added to the table. To construct the graphs, the mean values of displacements were used deduced from 10 identical experiments carried out under identical conditions, but with a uniform rotation of the cylindrical shell with respect to rigid stops, for each experiment.

Table 2 – Theoretical and empirical data related to the finding of displacements $u(P)$, $u_s(P)$, $v(P)$, $v_s(P)$ based on the known method [8]

ξ	0	0,2588	0,3420	0,3827	0,4226	0,5000	0,57
$E(\xi)$	1,5708	1,5442	1,5238	1,5116	1,4981	1,4675	1,4340
P, N	0	17,1	55,2	88,6	139,1	305,5	589,2
u, mm	0	2,60	4,66	5,93	7,33	10,64	14,42
u_s, mm	0	2,57	4,58	5,79	7,06	10,11	13,54
$\Delta_u, \%$	0	1,2	1,7	2,4	3,8	5,2	6,5
v, mm	0	2,65	4,75	6,03	7,51	11,04	15,12
v_s, mm	0	2,61	4,67	5,88	7,21	10,47	14,15
$\Delta_v, \%$	0	1,5	1,7	2,6	4,2	5,4	6,7

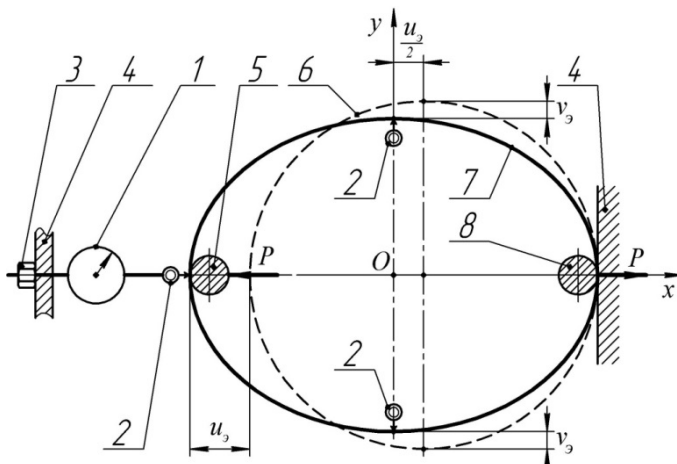

Figure 6 – Schematics of the flexible shell experimental stand (top view): 1 – indicator-type dynamometer DORM 0,1; 2 – hour indicators; 3 – adjusting nut to lock the specified load P (see the table); 4 – fixed supports; 5 – Rigid movable 5 and fixed 8 cylindrical stops; 6 – initial round shape of the shell at $P=0$; 7 – elliptical profile of the shell when $P>0$

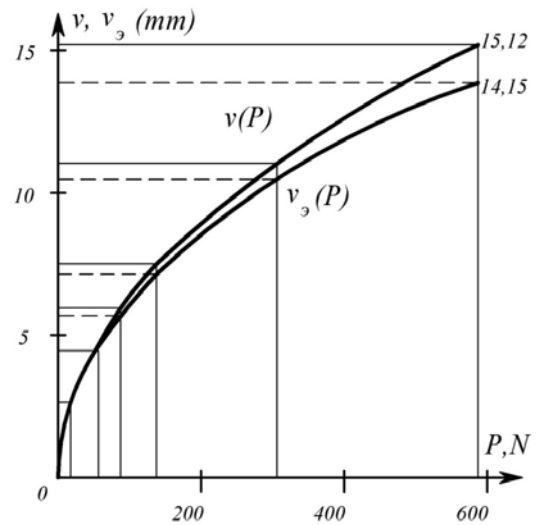

Figure 7 – External load P-dependency of the displacements $v(P)$, $v_s(P)$

To achieve the highest accuracy and experimental integrity, the stand is designed in such a way that practically excludes the impact of the shell weight when it is positioned horizontally, as well as friction, and deformation of related parts.

The results of the theory and its experimental check are summarized in table 2 and illustrated by graphs in figures 7 and 8.

In this case the letter symbols Δ_u , Δ_v are used to indicate values that qualify the deviation between the calculation u , v and experimental u_s , v_s kinematic parameters in per cents, depending on the external load

Figure 8 –
External load P-dependency
of kinematic parameters $u(P), u_3(P)$

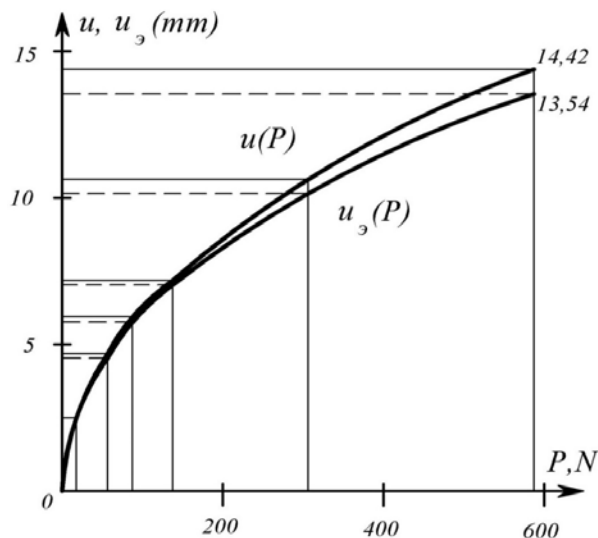

P to the shell (figures 2 and 3), the values of which (in N) are set in table 1 and recorded by a dynamometer (figures 3, 6).

Conclusions.

1. The experiment findings prove the feasibility of using the road roller shell with a variable contact area made of steel 30XГСА[3].

2. The research shows that the discrepancy between the overstated calculation u, v and experimental u_3, v_3 data, subject to the boundary in equation $0 \leq \xi \leq \xi_n$, ranged with in $\Delta_u = |u - u_3| \cdot u_3^{-1} \cdot 100 \% \leq 6,5\%$, $\Delta_v = |v - v_3| \cdot v_3^{-1} \cdot 100 \% \leq 6,7\%$. This means that the mechanical and mathematical model designed by the authors [2] to assess the strength of the variable-shape shell is a high quality and adequate model from the theoretical and calculation perspective.

3. Given the operation and process limitation $v \leq 0,1R_c$ is complied with, the experimental model of the steel thin-walled cylindrical shell (figure 3) was operating under the load P in an ideally elastic way, i.e. without any residual displacement when the highest normal tension σ_{max} did not exceed the yield limit σ_m of the material.

4. The experiment demonstrated that the surface of the shell had been deformed practically on an elliptical curve. This is convincing evidence showing the validity of using the ellipsis equation for the approximation of the shell.

5. As a result of the theoretical and practical studies of road roller flexible shells that adapt to the compacted material, the optimal variation range for the shell curvature in the contact area was determined. Exceeding of the range can lead to a loss of the roller initial shape and a failure of the ability to recover it after the load is removed.

6. The deformation and load of the roller shell let were found for different values of the curvature radius in the contact area.

7. The developed calculation algorithm for the allowable parameters of the shell deformation can be represented as an element of the base for the creation of an automated roller parameter selection system when designing different standard sizes of rollers or onboard roller system to control the reliability of the compaction parameters.

Acknowledgements. The authors would like to thank all the study participants. All authors have seen and approved the final version. Conflicts of interest: None declared.

REFERENCES

- [1] Pavlov V.V., Konyayev A.B. Road roller with a variable curvature leading roller // Construction and road machines. 1995. N 4. M., 1995: 23-25. (in Eng.).
- [2] Golovnin A.A. Vibratory road rollers: Construction. Theory and calculation. Case record: monograph [Text] / A.A. Golovnin. Tver: TSTU, 2002. 76 p. (in Russ.).
- [3] Maslov G.S., Zeltserman I.M., Konyayev A.B., Korolev V.A., Makarov-Zdrok V.A. Road roller. A.S. USSR No.

1096330, MKIZ E01C 19/29. Published 06/07/1984, Bul. No. 21. (in Eng.).

[4] Sakimov M.A., Golovnin A.A., Kuznetsov P.S. et al. Roller of road roller. Preliminary patent of Kazakhstan 18131. MPK E01C 19/26, E01C 19/23. Published bul. No. 12; 15.12.2006. (in Russ.).

[5] Guryanov G.A., Rechitskiy S.V., Andreyev F.V. Roller of road roller. Innovative patent of Kazakhstan No. 21592. MPK 7 E01C 19/26. publ. 14.08.2009, bul. No. 8. (in Russ.).

[6] Abdeyev B.M., Sakimov M.A. et al. Applied theory for the strength evaluation of the roller steel shell at changes in the curvature of a cylindrical guide. // D. Serikbaeva EKSTU Vestnik, No. 4. Ust-Kamenogorsk, 2011:27-36. (Part 1). http://www.ektu.kz/files/vestnik/tech04_2011.pdf(in Eng.).

[7] Doudkin M.V., Vavilov A.V., Pichugin S.Yu., Fadeev S.N. Calculation of the Interaction of Working Body of Road Machine with the Surface. Life Science Journal. 2013. Vol. 10. Issue 12. Article number 133:832-837. doi:10.7537/marslsj1012s13.133 (in Eng.).

[8] Doudkin M.V., Pichugin S.Yu., Fadeev S.N. The Analysis of Road Machine Working Elements Parameters // World Applied Sciences Journal. 2013. Vol. 23. Issue 2. P. 151-158. (ISSN / E-ISSN: 1818-4952/1991-6426). IDOSI Publications, 2013. DOI: 10.5829/idosi.wasj.2013.23.02.13061 (in Russ.).

[9] Popov E.P. Theory and calculation of flexible elastic rods. M.: Science, 1986. 296 p. (in Russ.).

[10] Zermina Gull Bhutta, Naem M.N., Imran M. On Vibration of Three-Layered Cylindrical Shell with Functionally Graded Middle Layer // American Journal of Applied Mathematics, 2015. 3(3-1): 32-40. Published online June 12, 2015 (<http://www.sciencepublishinggroup.com/j/ajam>)(in Eng.).

[11] Pichugin S.Yu., Fadeev S.N., Doudkin M.V. Studying the Machines for Road Maintenance // Life Science Journal. 2013. Vol. 10. Issue 12. Article number 24- P. 134-138. doi:10.7537/marslsj1012s13.24(in Eng.).

[12] Fadeev S.N., Pichugin S.Yu., Doudkin M.V. Contact Force Calculation of the Machine Operational Point // Life Science Journal. 2013. Vol. 10. Issue 10. Article number 39-P. 246-250. (ISSN:1097-8135). doi:10.7537/marslsj140817.39, <http://www.lifesciencesite.com>. 39(in Eng.).

[13] Xiangyu Li, Zhenduo Li, Minzu Liang. An Analytical Approach for Deformation Shapes of a Cylindrical Shell with Internal Medium Subjected to Lateral Contact Explosive Loading // Hindawi Publishing Corporation Mathematical Problems in Engineering. Volume 2015, Article ID 563097, 10 pages. <http://dx.doi.org/10.1155/2015/563097>.(in Eng.).

[14] Anoshiravan Farshidianfar, Pouria Oliazadeh. Free Vibration Analysis of Circular Cylindrical Shells: Comparison of Different Shell Theories. International Journal of Mechanics and Applications 2012, 2(5): 74-80. DOI: 10.5923/j.mechanics.20120205.04(in Eng.).

[15] Kim A., Doudkin M., Vavilov A., Guriyanov G. New vibroscreen with additional feed elements, Archives of Civil and Mechanical Engineering 17 (4) 2017:786-794 <http://doi.org/10.1016/j.acme.2017.02.009>.(in Eng.).

[16] Surashev N. et al., The Planetary Vibroexciter with Elliptic Inner Race, Advanced Materials Research, 2013:694-697:229-232, doi: 10.4028/ www.scientific.net/AMR.694-697/229.(in Eng.).

[17] Said D., Abd El Halim A.O., Pais J.C. Study of the Causes and Remedies of Premature Surface Cracking of Asphalt Pavements, EPAM3 // 3rd European Pavement and Asset Management Conference, Coimbra, Portugal, 7-9 July, 2008, (in Eng.).

[18] Abd El Halim, A.O., Haas R. (2004). Process and Case Illustration of Construction Innovation: From Concept to Commercial Realization, Journal of ASCE Construction Engineering and Management, 130:4:570-575, (in Eng.).

[19] Mostafa A., Halim A. O. A. (2004). Evaluating the Effect of Surface Cracks on Moisture Induced Damage Using Different Standard Test Methods for Airfield Asphalt Pavement Mixes, CTAA pp 318-339, Montreal, QC, (in Eng.).

[20] Ozhikenov K., Mikhailov P., Ismagulova R., Azamatova Z., Azamatov B. Development of technologies, methods and devices of the functional diagnostics of microelectronic sensors parts and components, 2016 13th International Scientific-Technical Conference on Actual Problems of Electronics Instrument Engineering (APEIE), Novosibirsk, Russia, 3-6 Oct. 2016, <http://ieeexplore.ieee.org/document/7802218/>, (in Eng.).

[21] Azamatov B., Ozhikenov K., Azamatova Z. Assessment of the effectiveness of the use of palladium in catalytic SHS-units for diesel engines, News of the National Academy of Sciences of the Republic of Kazakhstan, Volume 4, Number 424 (2017), pp. 142-147, <http://www.geolog-technical.kz/images/pdf/g20174/142147.pdf>, (in Eng.).

М. А. Сакимов¹, А. К. Ожикенова², Б. М. Абдеев¹, М. В. Дудкин¹, А. Қ. Өжікен², С. Азаматқызы¹

¹Әл-Фараби атындағы Қазақ ұлттық университеті, Алматы, Қазақстан,

²Д. Серікбаев атындағы Шығыс Қазақстан мемлекеттік техникалық университеті, Өскемен, Қазақстан

ҚАБЫҚШАСЫНЫҢ ҚИСЫҚТЫҒЫ ӨЗГЕРІЛМЕЛІ ЖОЛ АУНАҒЫ БІЛГІНІҢ ШЕКТІК ДЕФОРМАЦИЯЛАНУЫН АНЫҚТАУ

Аннотация. Тығыздау жұмыстарының басында, тығыздалатын материалдардың талап етілген қасиеттеріне қажет сипаттамаларға ие білікпен жабдықталған, жол аунағын таңдауға мүмкіндік беретін және оның беріктігін, сенімділігі мен тірек қабілетін бағалайтын, жол аунағының иілмелі білігі жағдайының жаңа механика-математикалық моделі қарастырылды. Мақала, жол аунақтарының құрылымында иілмелі қабықшаны қолданудың дұрыстығын және қабықшаны инженерлік жобалау мақсатында жеткілікті дәрежедегі дәлдікпен қолдануға болатын негізгі параметрлерін анықтауға және де ғылыми негіздеуге бағытталған. Қабықшасы, иілмелі болаттан жасалынған біліктен тұратын тәжірибелік жол аунағы мен сұлбалар, сонымен қатар натур-

дық құрылым ретінде практикалық қорытындылар келтірілген және де иілмелі қабықшаның параметрлерін зерттеуге арналған эксперименттік жабдық сипатталған. Қорытындылар ғылыми әдебиеттердегі ұқсас тапсырмалардың элементтік және аналитикалық шешімдерімен салыстырылып бұрынғы зерттеулерді біртұтас біріктіреді және толықтырады.

Түйін сөздер: цилиндрлік қабықшалар, серпімді деформация, дөңгелек сақинаның серпімді иілісі, жол аунағы білігінің иілмелі қабықшасы, тірек қабілеті, беріктік, кинематикалық параметрлері.

М. А. Сақимов¹, А. К. Ожикенова², Б. М. Абдеев¹, М. В. Дудкин¹, А. К. Ожикен², С. Азаматқызы¹

¹Восточно-Казахстанский государственный технический университет им. Д. Серикбаева,
Усть-Каменогорск, Казахстан,

²Казахский национальный университет им. аль-Фараби, Алматы, Казахстан

ОПРЕДЕЛЕНИЕ ДОПУСТИМЫХ ДЕФОРМАЦИЙ ВАЛЬЦА ДОРОЖНОГО КАТКА С ПЕРЕМЕННОЙ КРИВИЗНОЙ ОБЕЧАЙКИ

Аннотация. Рассмотрена новая механико-математическая модель состояния гибкой обечайки вальца дорожного катка, оценивающая её несущую способность, надежность и прочность, и позволяющая, в зависимости от свойств уплотняемого материала, еще до начала работ подобрать каток с требуемыми характеристиками уплотняющих вальцов. Рассмотрены вопросы допустимой трансформации круговой поверхности гибкой обечайки вальца и пределе ее допустимых перемещений, превышение которых приведет к общему срыву работоспособности вальца дорожного катка. Статья направлена на научное обоснование и установление целесообразности использования гибких обечаек в конструкциях вальцов дорожных катков и определения их параметров, которые можно с достаточной точностью использовать в целях инженерного проектирования. Описано экспериментальное оборудование для исследования параметров гибких обечаек и приведены практические результаты в виде схем и натурной конструкции, и опытного вальца дорожного катка с гибкой стальной обечайкой. Результаты дополняют и объединяются в целое с предыдущими исследованиями и сравниваются с аналитическими и элементными решениями аналогичных задач из научной литературы.

Ключевые слова: цилиндрические оболочки, упругая деформация, упругий изгиб круглого кольца, гибкая оболочка вальца дорожного катка, несущая способность, прочность, кинематические параметры.

Information about authors:

Sakimov M. A. – Master of Technical Sciences, East Kazakhstan state technical university named after D. Serikbayev, Ust-Kamenogorsk, Kazakhstan msakimov@mail.ru

Ozhikenova A. K. – PhD, Kazakh National University named after al-Farabi, Almaty, Kazakhstan, aiman84@mail.ru.

Abdeyev B. M. – Candidate of technical sciences, associate professor, East Kazakhstan state technical university named after D. Serikbayev, Ust-Kamenogorsk, Kazakhstan, m.abdeyeva@mail.ru

Dudkin M. V. – Doctor of technical sciences, associate professor, Kazakhstan state technical university named after D. Serikbayev, Ust-Kamenogorsk, Kazakhstan, doudkin@mail.ru.

Ozhiken A. K. – Doctoral student 2 courses, Kazakh National University named after al-Farabi, Almaty, Kazakhstan, ozhiken11@gmail.com.

Azamatkyzy S. – Master of Technical Sciences, Senior Lecturer, East Kazakhstan state technical university named after D. Serikbayev, Ust-Kamenogorsk, Kazakhstan, asamal-0107@mail.ru.

Publication Ethics and Publication Malpractice in the journals of the National Academy of Sciences of the Republic of Kazakhstan

For information on Ethics in publishing and Ethical guidelines for journal publication see <http://www.elsevier.com/publishingethics> and <http://www.elsevier.com/journal-authors/ethics>.

Submission of an article to the National Academy of Sciences of the Republic of Kazakhstan implies that the described work has not been published previously (except in the form of an abstract or as part of a published lecture or academic thesis or as an electronic preprint, see <http://www.elsevier.com/postingpolicy>), that it is not under consideration for publication elsewhere, that its publication is approved by all authors and tacitly or explicitly by the responsible authorities where the work was carried out, and that, if accepted, it will not be published elsewhere in the same form, in English or in any other language, including electronically without the written consent of the copyright-holder. In particular, translations into English of papers already published in another language are not accepted.

No other forms of scientific misconduct are allowed, such as plagiarism, falsification, fraudulent data, incorrect interpretation of other works, incorrect citations, etc. The National Academy of Sciences of the Republic of Kazakhstan follows the Code of Conduct of the Committee on Publication Ethics (COPE), and follows the COPE Flowcharts for Resolving Cases of Suspected Misconduct (http://publicationethics.org/files/u2/New_Code.pdf). To verify originality, your article may be checked by the Cross Check originality detection service <http://www.elsevier.com/editors/plagdetect>.

The authors are obliged to participate in peer review process and be ready to provide corrections, clarifications, retractions and apologies when needed. All authors of a paper should have significantly contributed to the research.

The reviewers should provide objective judgments and should point out relevant published works which are not yet cited. Reviewed articles should be treated confidentially. The reviewers will be chosen in such a way that there is no conflict of interests with respect to the research, the authors and/or the research funders.

The editors have complete responsibility and authority to reject or accept a paper, and they will only accept a paper when reasonably certain. They will preserve anonymity of reviewers and promote publication of corrections, clarifications, retractions and apologies when needed. The acceptance of a paper automatically implies the copyright transfer to the National Academy of Sciences of the Republic of Kazakhstan.

The Editorial Board of the National Academy of Sciences of the Republic of Kazakhstan will monitor and safeguard publishing ethics.

Правила оформления статьи для публикации в журнале смотреть на сайте:

www.nauka-nanrk.kz

ISSN 2518-170X (Online), ISSN 2224-5278 (Print)

<http://geolog-technical.kz/index.php/kz/>

Верстка Д. Н. Калкабековой

Подписано в печать 14.05.2018.
Формат 70x881/8. Бумага офсетная. Печать – ризограф.
24,2 п.л. Тираж 300. Заказ 3.