

ISSN 2518-170X (Online),  
ISSN 2224-5278 (Print)

ҚАЗАҚСТАН РЕСПУБЛИКАСЫ  
ҰЛТТЫҚ ҒЫЛЫМ АКАДЕМИЯСЫНЫҢ  
Қ. И. Сәтпаев атындағы Қазақ ұлттық техникалық зерттеу университеті

# Х А Б А Р Л А Р Ы

## ИЗВЕСТИЯ

НАЦИОНАЛЬНОЙ АКАДЕМИИ НАУК  
РЕСПУБЛИКИ КАЗАХСТАН  
Казахский национальный исследовательский  
технический университет им. К. И. Сатпаева

## NEWS

OF THE ACADEMY OF SCIENCES  
OF THE REPUBLIC OF KAZAKHSTAN  
Kazakh national research technical university  
named after K. I. Satpayev

### ГЕОЛОГИЯ ЖӘНЕ ТЕХНИКАЛЫҚ ҒЫЛЫМДАР СЕРИЯСЫ



### СЕРИЯ ГЕОЛОГИИ И ТЕХНИЧЕСКИХ НАУК



### SERIES OF GEOLOGY AND TECHNICAL SCIENCES

**1 (427)**

ҚАҢТАР – АҚПАН 2018 ж.  
ЯНВАРЬ – ФЕВРАЛЬ 2018 г.  
JANUARY – FEBRUARY 2018

ЖУРНАЛ 1940 ЖЫЛДАН ШЫҒА БАСТАҒАН  
ЖУРНАЛ ИЗДАЕТСЯ С 1940 г.  
THE JOURNAL WAS FOUNDED IN 1940.

ЖЫЛЫНА 6 РЕТ ШЫҒАДЫ  
ВЫХОДИТ 6 РАЗ В ГОД  
PUBLISHED 6 TIMES A YEAR

---

*NAS RK is pleased to announce that News of NAS RK. Series of geology and technical sciences scientific journal has been accepted for indexing in the Emerging Sources Citation Index, a new edition of Web of Science. Content in this index is under consideration by Clarivate Analytics to be accepted in the Science Citation Index Expanded, the Social Sciences Citation Index, and the Arts & Humanities Citation Index. The quality and depth of content Web of Science offers to researchers, authors, publishers, and institutions sets it apart from other research databases. The inclusion of News of NAS RK. Series of geology and technical sciences in the Emerging Sources Citation Index demonstrates our dedication to providing the most relevant and influential content of geology and engineering sciences to our community.*

*Қазақстан Республикасы Ұлттық ғылым академиясы "ҚР ҰҒА Хабарлары. Геология және техникалық ғылымдар сериясы" ғылыми журналының Web of Science-тің жаңаланған нұсқасы Emerging Sources Citation Index-те индекстелуге қабылданғанын хабарлайды. Бұл индекстелу барысында Clarivate Analytics компаниясы журналды одан әрі the Science Citation Index Expanded, the Social Sciences Citation Index және the Arts & Humanities Citation Index-ке қабылдау мәселесін қарастыруда. Web of Science зерттеушілер, авторлар, баспашылар мен мекемелерге контент тереңдігі мен сапасын ұсынады. ҚР ҰҒА Хабарлары. Геология және техникалық ғылымдар сериясы Emerging Sources Citation Index-ке енуі біздің қоғамдастық үшін ең өзекті және беделді геология және техникалық ғылымдар бойынша контентке адалдығымызды білдіреді.*

*НАН РК сообщает, что научный журнал «Известия НАН РК. Серия геологии и технических наук» был принят для индексирования в Emerging Sources Citation Index, обновленной версии Web of Science. Содержание в этом индексировании находится в стадии рассмотрения компанией Clarivate Analytics для дальнейшего принятия журнала в the Science Citation Index Expanded, the Social Sciences Citation Index и the Arts & Humanities Citation Index. Web of Science предлагает качество и глубину контента для исследователей, авторов, издателей и учреждений. Включение Известия НАН РК. Серия геологии и технических наук в Emerging Sources Citation Index демонстрирует нашу приверженность к наиболее актуальному и влиятельному контенту по геологии и техническим наукам для нашего сообщества.*

Б а с р е д а к т о р ы  
э. ғ. д., профессор, ҚР ҰҒА академигі

**И.К. Бейсембетов**

Бас редакторының орынбасары

**Жолтаев Г.Ж.** проф., геол.-мин. ғ. докторы

Р е д а к ц и я а л қ а с ы:

**Абаканов Т.Д.** проф. (Қазақстан)  
**Абишева З.С.** проф., академик (Қазақстан)  
**Агабеков В.Е.** академик (Беларусь)  
**Алиев Т.** проф., академик (Әзірбайжан)  
**Бакиров А.Б.** проф., (Қырғыстан)  
**Беспәев Х.А.** проф. (Қазақстан)  
**Бишимбаев В.К.** проф., академик (Қазақстан)  
**Буктуков Н.С.** проф., академик (Қазақстан)  
**Булат А.Ф.** проф., академик (Украина)  
**Ганиев И.Н.** проф., академик (Тәжікстан)  
**Грэвис Р.М.** проф. (АҚШ)  
**Ерғалиев Г.К.** проф., академик (Қазақстан)  
**Жуков Н.М.** проф. (Қазақстан)  
**Кенжалиев Б.К.** проф. (Қазақстан)  
**Қожахметов С.М.** проф., академик (Қазақстан)  
**Конторович А.Э.** проф., академик (Ресей)  
**Курскеев А.К.** проф., академик (Қазақстан)  
**Курчавов А.М.** проф., (Ресей)  
**Медеу А.Р.** проф., академик (Қазақстан)  
**Мұхамеджанов М.А.** проф., корр.-мүшесі (Қазақстан)  
**Нигматова С.А.** проф. (Қазақстан)  
**Оздоев С.М.** проф., академик (Қазақстан)  
**Постолатий В.** проф., академик (Молдова)  
**Ракишев Б.Р.** проф., академик (Қазақстан)  
**Сейтов Н.С.** проф., корр.-мүшесі (Қазақстан)  
**Сейтмуратова Э.Ю.** проф., корр.-мүшесі (Қазақстан)  
**Степанец В.Г.** проф., (Германия)  
**Хамфери Дж.Д.** проф. (АҚШ)  
**Штейнер М.** проф. (Германия)

«ҚР ҰҒА Хабарлары. Геология мен техникалық ғылымдар сериясы».

**ISSN 2518-170X (Online),**

**ISSN 2224-5278 (Print)**

Меншіктенуші: «Қазақстан Республикасының Ұлттық ғылым академиясы» РҚБ (Алматы қ.).

Қазақстан республикасының Мәдениет пен ақпарат министрлігінің Ақпарат және мұрағат комитетінде 30.04.2010 ж. берілген №10892-Ж мерзімдік басылым тіркеуіне қойылу туралы куәлік.

Мерзімділігі: жылына 6 рет.

Тиражы: 300 дана.

Редакцияның мекенжайы: 050010, Алматы қ., Шевченко көш., 28, 219 бөл., 220, тел.: 272-13-19, 272-13-18,  
<http://nauka-nanrk.kz/geology-technical.kz>

---

© Қазақстан Республикасының Ұлттық ғылым академиясы, 2018

Редакцияның Қазақстан, 050010, Алматы қ., Қабанбай батыра көш., 69а.

мекенжайы: Қ. И. Сәтбаев атындағы геология ғылымдар институты, 334 бөлме. Тел.: 291-59-38.

Типографияның мекенжайы: «Аруна» ЖК, Алматы қ., Муратбаева көш., 75.

Г л а в н ы й р е д а к т о р  
д. э. н., профессор, академик НАН РК

**И. К. Бейсембетов**

Заместитель главного редактора

**Жолтаев Г.Ж.** проф., доктор геол.-мин. наук

Р е д а к ц и о н н а я к о л л е г и я:

**Абаканов Т.Д.** проф. (Казахстан)  
**Абишева З.С.** проф., академик (Казахстан)  
**Агабеков В.Е.** академик (Беларусь)  
**Алиев Т.** проф., академик (Азербайджан)  
**Бакиров А.Б.** проф., (Кыргызстан)  
**Беспаяев Х.А.** проф. (Казахстан)  
**Бишимбаев В.К.** проф., академик (Казахстан)  
**Буктуков Н.С.** проф., академик (Казахстан)  
**Булат А.Ф.** проф., академик (Украина)  
**Ганиев И.Н.** проф., академик (Таджикистан)  
**Грэвис Р.М.** проф. (США)  
**Ергалиев Г.К.** проф., академик (Казахстан)  
**Жуков Н.М.** проф. (Казахстан)  
**Кенжалиев Б.К.** проф. (Казахстан)  
**Кожаметов С.М.** проф., академик (Казахстан)  
**Конторович А.Э.** проф., академик (Россия)  
**Курскеев А.К.** проф., академик (Казахстан)  
**Курчавов А.М.** проф., (Россия)  
**Медеу А.Р.** проф., академик (Казахстан)  
**Мухамеджанов М.А.** проф., чл.-корр. (Казахстан)  
**Нигматова С.А.** проф. (Казахстан)  
**Оздоев С.М.** проф., академик (Казахстан)  
**Постолатий В.** проф., академик (Молдова)  
**Ракишев Б.Р.** проф., академик (Казахстан)  
**Сейтов Н.С.** проф., чл.-корр. (Казахстан)  
**Сейтмуратова Э.Ю.** проф., чл.-корр. (Казахстан)  
**Степанец В.Г.** проф., (Германия)  
**Хамфери Дж.Д.** проф. (США)  
**Штейнер М.** проф. (Германия)

«Известия НАН РК. Серия геологии и технических наук».

**ISSN 2518-170X (Online),**

**ISSN 2224-5278 (Print)**

Собственник: Республиканское общественное объединение «Национальная академия наук Республики Казахстан (г. Алматы)

Свидетельство о постановке на учет периодического печатного издания в Комитете информации и архивов Министерства культуры и информации Республики Казахстан №10892-Ж, выданное 30.04.2010 г.

Периодичность: 6 раз в год

Тираж: 300 экземпляров

Адрес редакции: 050010, г. Алматы, ул. Шевченко, 28, ком. 219, 220, тел.: 272-13-19, 272-13-18,  
<http://nauka-nanrk.kz/geology-technical.kz>

---

© Национальная академия наук Республики Казахстан, 2018

Адрес редакции: Казахстан, 050010, г. Алматы, ул. Кабанбай батыра, 69а.

Институт геологических наук им. К. И. Сатпаева, комната 334. Тел.: 291-59-38.

Адрес типографии: ИП «Аруна», г. Алматы, ул. Муратбаева, 75

Editor in chief

doctor of Economics, professor, academician of NAS RK

**I. K. Beisembetov**

Deputy editor in chief

**Zholtayev G.Zh.** prof., dr. geol-min. sc.

Editorial board:

**Abakanov T.D.** prof. (Kazakhstan)  
**Abisheva Z.S.** prof., academician (Kazakhstan)  
**Agabekov V.Ye.** academician (Belarus)  
**Aliyev T.** prof., academician (Azerbaijan)  
**Bakirov A.B.** prof., (Kyrgyzstan)  
**Bespayev Kh.A.** prof. (Kazakhstan)  
**Bishimbayev V.K.** prof., academician (Kazakhstan)  
**Buktukov N.S.** prof., academician (Kazakhstan)  
**Bulat A.F.** prof., academician (Ukraine)  
**Ganiyev I.N.** prof., academician (Tadjikistan)  
**Gravis R.M.** prof. (USA)  
**Yergaliev G.K.** prof., academician (Kazakhstan)  
**Zhukov N.M.** prof. (Kazakhstan)  
**Kenzhaliyev B.K.** prof. (Kazakhstan)  
**Kozhakhmetov S.M.** prof., academician (Kazakhstan)  
**Kontorovich A.Ye.** prof., academician (Russia)  
**Kurskeyev A.K.** prof., academician (Kazakhstan)  
**Kurchavov A.M.** prof., (Russia)  
**Medeu A.R.** prof., academician (Kazakhstan)  
**Muhamedzhanov M.A.** prof., corr. member. (Kazakhstan)  
**Nigmatova S.A.** prof. (Kazakhstan)  
**Ozdoev S.M.** prof., academician (Kazakhstan)  
**Postolatii V.** prof., academician (Moldova)  
**Rakishev B.R.** prof., academician (Kazakhstan)  
**Seitov N.S.** prof., corr. member. (Kazakhstan)  
**Seitmuratova Ye.U.** prof., corr. member. (Kazakhstan)  
**Stepanets V.G.** prof., (Germany)  
**Humphery G.D.** prof. (USA)  
**Steiner M.** prof. (Germany)

**News of the National Academy of Sciences of the Republic of Kazakhstan. Series of geology and technology sciences.**

**ISSN 2518-170X (Online),**

**ISSN 2224-5278 (Print)**

Owner: RPA "National Academy of Sciences of the Republic of Kazakhstan" (Almaty)

The certificate of registration of a periodic printed publication in the Committee of information and archives of the Ministry of culture and information of the Republic of Kazakhstan N 10892-Ж, issued 30.04.2010

Periodicity: 6 times a year

Circulation: 300 copies

Editorial address: 28, Shevchenko str., of. 219, 220, Almaty, 050010, tel. 272-13-19, 272-13-18,  
<http://nauka-nanrk.kz/geology-technical.kz>

---

© National Academy of Sciences of the Republic of Kazakhstan, 2018

Editorial address: Institute of Geological Sciences named after K.I. Satpayev  
69a, Kabanbai batyr str., of. 334, Almaty, 050010, Kazakhstan, tel.: 291-59-38.

Address of printing house: ST "Aruna", 75, Muratbayev str, Almaty

## NEWS

OF THE NATIONAL ACADEMY OF SCIENCES OF THE REPUBLIC OF KAZAKHSTAN

SERIES OF GEOLOGY AND TECHNICAL SCIENCES

ISSN 2224-5278

Volume 1, Number 427 (2018), 111 – 117

UDC 621.01

**B. Sinchev<sup>1</sup>, A. M. Mukhanova<sup>2</sup>**<sup>1</sup>International University of Information Technology, Almaty, Kazakhstan<sup>2</sup>Almaty Technological University, Almaty, Kazakhstan

E-mail:sinchev@mail.ru, nuraksulu72@mail.ru

**THE DESIGN OF UNIQUE MECHANISMS AND MACHINES. I.**

**Abstract.** This work is devoted to the development of numerical methods of calculating the kinematic and dynamic parameters for the design of a new mechanism of class IV based on equations kinematics and dynamics. Kinematic and dynamic models of these mechanisms are described by differential-algebraic equations. These equations are singular differential equations. For the first time, we consider the analysis of dynamics and kinematics for mechanisms of high class in a joint formulation. A cardinal breakthrough is possible in the transition of mechanisms of lower class to high class to design new mechanisms and machines. A new concept based on Runge-Kutta method is offered for mechanisms of high class aimed at solving kinematic - dynamic model. Methods, algorithms and programs are developed to define the position and the speed of links for mechanism of class IV at any given accuracy. A numerical experiment has shown a huge advantage of mechanism of class IV to design a new mechanism for mechanical engineering and robotics.

**Keywords:** kinematics, dynamics, mechanism of high class, mechanical engineering, robotics.

**Introduction.** The modern theory of analysis and synthesis for lever mechanisms of lower class (class II) is complete and their features are studied and used in practice. Therefore, a significant breakthrough in the design of new machinery and equipment is possible in the way of upgrading the facility.

The exploration of mechanisms of high class was started with well-known Assyria's work [1]. Academicians Artobolevsky I.I. [2], Zholdasbekov U.A. [3] and a lot of other scientists made their contribution into the further development of the theory of those mechanisms. In these works, the benefits of mechanisms of high class compared with mechanisms of lower class (class II) were established based on geometric and approximate methods.

The kinematic-dynamic model for mechanism of high class is described by differential-algebraic equations (DAE). Some questions of the investigation of DAE are given in [4-6].

The complete analysis of mechanisms of high class involves the simultaneous solution of kinematic and dynamic problems. According to the classical theory of mechanisms and machines, a separate solution of complex problems is considered. Planar lever mechanism of class IV as the basic mechanism out of all mechanisms of high class and in much the same way a four-link mechanism out of mechanisms of lower class II are going to be studied.

This work is devoted to the development of a new calculation theory for the underlying mechanism of class IV done based on the theory of differential equations.

In the second part of this work, we consider singular differential-algebraic equations and a power analysis of these mechanisms.

The proposed methods, algorithms and the held computational experiment made possibilities to identify the unique characteristics of the above mentioned mechanism of class IV and their use in various scientific and technological fields (in the mechanisms like departure chassis of an aircraft, load-lifting cranes, presses, robots and other devices).

**The common model for mechanism of high class.** Suppose the mechanism of high class (MHC) consists of  $n$  moving links. Numbers of output links vary from 1 to  $n-m$ , and the number of input ones

varies from  $n-m+1$  to  $n$ ,  $m$  is the number of input links directly related to drive units (Figure 1). The proposed mechanism of the numbering units enables the use of vector-matrix notation in solving various equations in kinematics and dynamics.

Then the general model for mechanism of class IV ( $n=6, m=2$ ) is represented in the form:

– differential equations of this mechanism's dynamics having two degrees of freedom (two generalized coordinates) are:

$$L''_{\vec{\varphi}_k \vec{\varphi}_k}(\vec{\varphi}, \dot{\vec{\varphi}})\ddot{\vec{\varphi}}_k + L'_{\vec{\varphi}_k \vec{\varphi}_k}(\vec{\varphi}, \dot{\vec{\varphi}})\dot{\vec{\varphi}}_k + L'_{\vec{\varphi}_k}(\vec{\varphi}, \dot{\vec{\varphi}}) = Q_k, \quad (1)$$

and having the initial conditions

$$\vec{\varphi}_k(t_0) = \vec{\varphi}_k^0, \dot{\vec{\varphi}}_k(t_0) = \dot{\vec{\varphi}}_k^0, k=5,6 \quad (2)$$

equations of kinematics in the differential form are

$$\begin{pmatrix} \dot{\varphi}_1 \\ \dot{\varphi}_2 \\ \dot{\varphi}_3 \\ \dot{\varphi}_4 \end{pmatrix} = \begin{pmatrix} a_{11} & a_{12} & a_{13} & a_{14} \\ a_{21} & a_{22} & a_{23} & a_{24} \\ a_{31} & a_{32} & a_{33} & a_{34} \\ a_{41} & a_{42} & a_{43} & a_{44} \end{pmatrix}^{-1} \begin{pmatrix} b_{11} & b_{12} \\ b_{21} & b_{22} \\ b_{31} & b_{32} \\ b_{41} & b_{42} \end{pmatrix} \begin{pmatrix} \dot{\varphi}_5 \\ \dot{\varphi}_6 \end{pmatrix} \quad (3)$$

where  $a_{11} = l_1 y_1$ ,  $a_{12} = l_2 y_2$ ,  $a_{13} = l_3 y_3$ ,  $a_{14} = 0$ ,  $a_{21} = l_1 x_1$ ,  $a_{22} = l_2 x_2$ ,  $a_{23} = l_3 x_3$ ,  $a_{24} = 0$ ,  $a_{31} = l_1^* y_1^*$ ,  $a_{32} = 0$ ,  $a_{33} = l_3^* y_3^*$ ,  $a_{34} = l_4 y_4$ ,  $a_{41} = l_1^* x_1^*$ ,  $a_{42} = 0$ ,  $a_{43} = l_3^* x_3^*$ ,  $a_{44} = l_4 x_4$ ,  $b_{11} = l_6 y_6$ ,  $b_{12} = -l_5 y_5$ ,  $b_{21} = l_6 x_6$ ,  $b_{22} = -l_5 x_5$ ,  $b_{31} = b_{11}$ ,  $b_{32} = b_{12}$ ,  $b_{41} = b_{21}$ ,  $b_{42} = b_{22}$ ,

$$A = \begin{pmatrix} a_{11} & a_{12} & a_{13} & a_{14} \\ a_{21} & a_{22} & a_{23} & a_{24} \\ a_{31} & a_{32} & a_{33} & a_{34} \\ a_{41} & a_{42} & a_{43} & a_{44} \end{pmatrix}.$$

Here, we introduce the following notation:  $\vec{\varphi}, \dot{\vec{\varphi}}$  are the vectors of the angular coordinates and velocity of the input links 5 and 6;  $x_i = \cos \varphi_i, y_i = \sin \varphi_i$ ,  $\varphi_i$  are the rectangular and angular coordinates of output links ( $i=1,2,3,4$ );  $x_1^* = \cos(\varphi_1 \pm \alpha_1)$ ,  $y_1^* = \sin(\varphi_1 \pm \alpha_1)$ ,  $x_3^* = \cos(\varphi_3 \pm \alpha_3)$ ,  $y_3^* = \sin(\varphi_3 \pm \alpha_3)$  – are the rectangular coordinates of basic links 1 and 3,  $Q_5, Q_6$  are coerced moments to input (leading) links.  $L$  is Lagrange function (Lagrangian),

$$L = K - P = \frac{1}{2} \dot{\vec{q}}' H(\vec{q}) \dot{\vec{q}} - \vec{m}' \vec{h} * g,$$

where  $\vec{m}$  are vectors of masses of mechanism's moving links,  $\vec{m}, \vec{h}$  are vectors of dimension  $n$ ,  $\vec{h} = \vec{l} \sin \vec{\varphi}$ ,  $\vec{l}$  is the vector of moving links for the mechanism of class IV, which is determined by the equations of kinematics,  $H(\vec{q})$  is the order matrix  $n \times n$  of the whole mechanism's kinetic energy,  $g$  is a gravitational acceleration. According to S. Koenig theory we define that for mechanism of class IV the Lagrangian  $L = K - P$  which consists of kinetic and potential energies.

**Task 1.** Solve the general model (1) - (3) for mechanism of class IV using Runge-Kutta's method for  $|A| \neq 0$ .

The solution of the problem allows determining position and speed of all links for this mechanism in the time interval  $T = t_1 - t_0$ . However, even in the determination of the Lagrange operator of type II (complete calculation of the system's coefficients (1)) you cannot apply Runge-Kutta's method to the joint decision of systems of differential equations (1) and (3), since initial conditions (initial values of angular coordinates of output units 1-4) are unknown in the system (3). In the beginning, we have to find initial conditions

$$\varphi_1(t_0), \varphi_2(t_0), \varphi_3(t_0), \varphi_4(t_0) \quad (4)$$

starting with kinematic (trigonometric) equations:

$$\begin{aligned} l_1 \cos \varphi_1 + l_2 \cos \varphi_2 + l_3 \cos \varphi_3 + l_5 \cos \varphi_5 - l_6 \cos \varphi_6 - l_0 \cos \varphi_0 &= 0 \\ l_1 \sin \varphi_1 + l_2 \sin \varphi_2 + l_3 \sin \varphi_3 + l_5 \sin \varphi_5 - l_6 \sin \varphi_6 - l_0 \sin \varphi_0 &= 0 \\ l_1^* \cos(\varphi_1 - \alpha_1) - l_3^* \cos(\varphi_3 + \alpha_3) + l_4 \cos \varphi_4 + l_5 \cos \varphi_5 - l_6 \cos \varphi_6 - l_0 \cos \varphi_0 &= 0 \\ l_1^* \sin(\varphi_1 - \alpha_1) - l_3^* \sin(\varphi_3 + \alpha_3) + l_4 \sin \varphi_4 + l_5 \sin \varphi_5 - l_6 \sin \varphi_6 - l_0 \sin \varphi_0 &= 0 \end{aligned} \quad (5)$$

Thus, a general model (1), (3) of mechanism of class IV can be represented by a system of differential equations of order  $n + 2m$  in the normal form of Cauchy:

$$\dot{x} = \vec{f}(x, t) \quad (6)$$

Having the initial conditions

$$x(t_0) = x_0, \quad (7)$$

where  $\vec{f}(x, t)$  is the known vector-function of dimension  $n + 2m$ ,  $x_1 = \varphi_1, x_2 = \varphi_2, x_3 = \varphi_3, x_4 = \varphi_4, x_5 = \varphi_5, x_6 = \varphi_6, x_7 = \dot{\varphi}_5, x_8 = \dot{\varphi}_6, n = 4, m = 2$ .

The equations of the system (6) are represented by differential equations (3) of the kinematics and dynamics (1) in normal form of Cauchy. The initial conditions (9) of the system of differential equations (6) are equal to initial conditions (4) and (2). In these differential equations (6) the mass and inertia characteristics of mechanism of class IV are taken into account. Finally, the positions and velocities of all the moving links of mechanism of class IV are defined addressing the system of differential equations (6) having the initial conditions (7) using Runge-Kutta's method. At the same time, the solutions must satisfy the equations of kinematics (5), otherwise we have to use Runge-Kutta's method with a variable step. This is a brief essence of the proposed method of immersion.

**The kinematic method for the mechanism of class IV.** We go to the determination of initial values of angular coordinates (4) of output links 1-4 when initial values of angular coordinates (3) of input links 5 and 6 for the mechanism of class IV are given. We just note that the differential equations (3) are derived from the trigonometric equations (5) describing the positions of links for mechanism of class IV.

**Task 2.** Define the initial values of the angular coordinates of output links 1-4 of mechanism of class IV at the initial value of the angular coordinate input links 5 and 6.

Excluding the angular coordinates  $\varphi_2$  and  $\varphi_4$  the system (5) takes the form:

$$\begin{aligned} A_1 x_1 + B_1 y_1 &= C_1 \\ A_2 x_1 + B_2 y_1 &= C_2 \\ x_1^2 + y_1^2 &= 1, \end{aligned} \quad (8)$$

where

$$\begin{aligned} x_1^* &= x_1 \cos \alpha_1 + y_1 \sin \alpha_1, & y_1^* &= x_1 \sin \alpha_1 - y_1 \cos \alpha_1, \\ x_3^* &= x_3 \cos \alpha_3 - y_3 \sin \alpha_3, & y_3^* &= x_3 \sin \alpha_3 + y_3 \cos \alpha_3, \\ A_1 &= 2(-l_3 x_3 + l_5 x_5 - l_6 x_6 - l_0 x_0) l_1, & B_1 &= 2(-l_3 y_3 + l_5 y_5 - l_6 y_6 - l_0 y_0) l_1 \\ C_1 &= l_2^2 - l_1^2 - l_3^2 - (l_5 x_5 - l_6 x_6 - l_0 x_0)^2 - (l_5 y_5 - l_6 y_6 - l_0 y_0)^2 + \\ &+ 2l_3 x_3 (l_5 x_5 - l_6 x_6 - l_0 x_0) + 2l_3 y_3 (l_5 y_5 - l_6 y_6 - l_0 y_0), \\ A_2 &= 2(-l_3^* x_3 + l_5 x_5 - l_6 x_6 - l_0 x_0) l_1^* \cos \alpha_1 - 2(-l_3^* y_3 + l_5 y_5 - l_6 y_6 - l_0 y_0) l_1^* \sin \alpha_1, \\ B_2 &= 2(-l_3^* x_3 + l_5 x_5 - l_6 x_6 - l_0 x_0) l_1^* \sin \alpha_1 + 2(-l_3^* y_3 + l_5 y_5 - l_6 y_6 - l_0 y_0) l_1^* \cos \alpha_1, \\ C_2 &= l_4^2 - l_1^{*2} - l_3^{*2} - (l_5 x_5 - l_6 x_6 - l_0 x_0)^2 - (l_5 y_5 - l_6 y_6 - l_0 y_0)^2 + \\ &+ 2l_3^* (l_5 x_5 - l_6 x_6 - l_0 x_0) x_3^* + 2l_3^* (l_5 y_5 - l_6 y_6 - l_0 y_0) y_3^*. \end{aligned}$$

The originality of the approach [7] is to switch from the system (8) after an application of the universal substitution to the system of quadratic equations:

$$\begin{aligned} (A_1 + C_1)u^2 - 2B_1 u + C_1 - A_1 &= 0 \\ (A_2 + C_2)u^2 - 2B_2 u + C_2 - A_2 &= 0. \end{aligned} \quad (9)$$

Initially, we must determine the real solution of the nonlinear system (9). For this purpose, we define the discriminants of the equations (9)

$$D_1 = A_1^2 + B_1^2 - C_1^2, \quad D_2 = A_2^2 + B_2^2 - C_2^2$$



and conditions of the system solutions' reality (8)

$$D_1 > 0, D_2 > 0, \text{ or } D_1 \geq 0, D_2 > 0, \text{ or } D_1 > 0, D_2 \geq 0.$$

Discriminants are algebraic inequalities of the fourth degree regarding the variable  $x_3 = \cos\varphi_3$  or  $y_3 = \sin\varphi_3$ . Therefore, it is easy to determine this variable's exact ranges based on higher algebra.

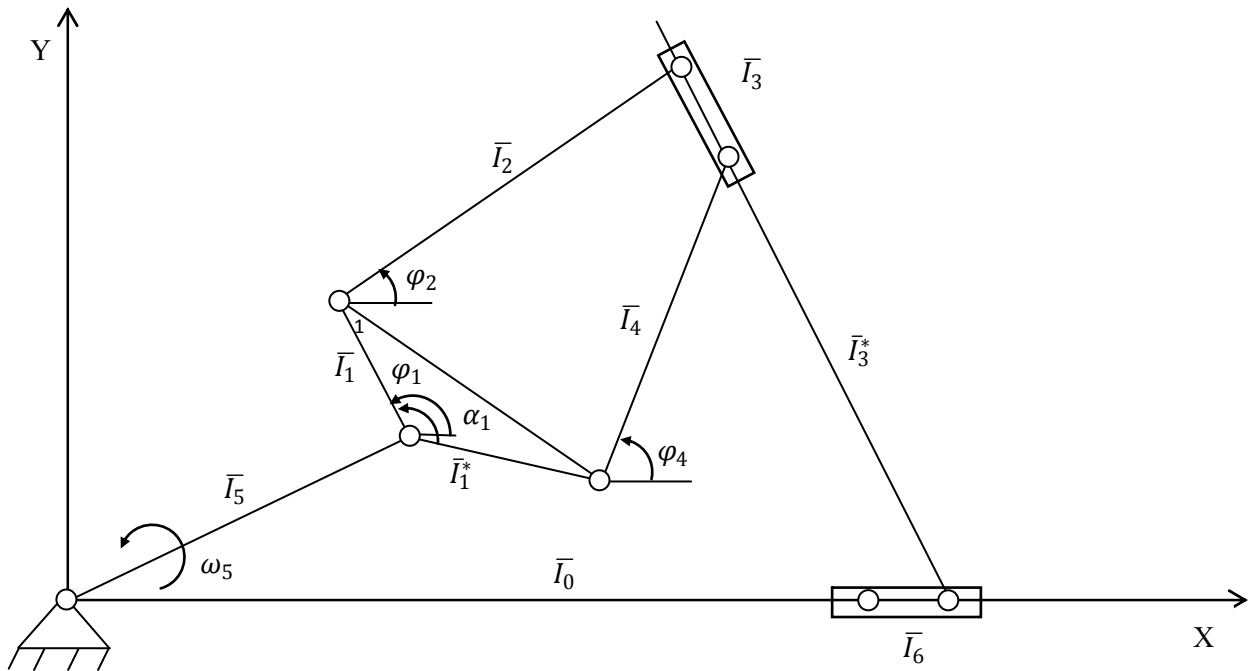
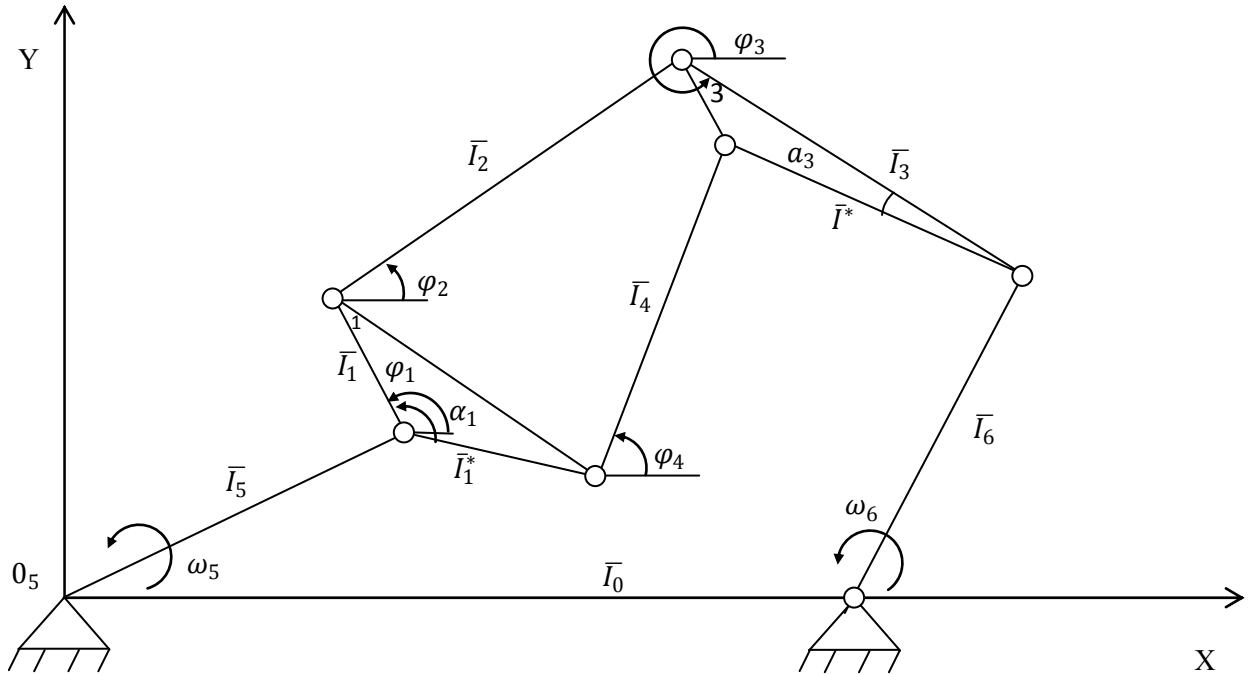

Mechanism of class IV having rotational and serial pairs

**The common algorithm for solving the dynamic and kinematic problems of the mechanism of class IV.** Fundamentals of the above offered theory have formed the basis of algorithms and programs determining dynamic and kinematic parameters of the mechanism of class IV.

**Step 1.** Input of data:  $\varphi(t_0) = \varphi_5^0$ ,

$$l_0, l_1, l_2, l_3, l_4, l_5, l_1^*, l_3^*, \alpha_1, \alpha_3, l_6 = 0.$$

**Step 2.** Determination of the initial conditions  $\varphi_1(t_0), \varphi_2(t_0), \varphi_3(t_0), \varphi_4(t_0)$  on the basis of the method of kinematics (10)-(12)

**Step 3.** Start Runge-Kutta's method to determine all angular coordinates and speeds for the mechanism of class IV:

$$\varphi_1(t_0), \varphi_2(t_0), \varphi_3(t_0), \varphi_4(t_0) \text{ and } \dot{\varphi}_1(t_0), \dot{\varphi}_2(t_0), \dot{\varphi}_3(t_0), \dot{\varphi}_4(t_0)$$

**Step 4.** Output of results.

We found the position, speed of links and reaction forces in joints for mechanism of class IV on the basis of the developed programs.

**Discussion of results.** Initially, we represent the scientific value of the developed analytical methods for calculating kinematic and dynamic parameters of mechanism of high class. For the first time necessary and sufficient conditions for the existence of real solutions of the kinematic and dynamic general model describing the position, speed and inertia characteristics of all moving parts of the mechanism of class IV have been found.

Kinematic and dynamic tasks are reduced to the study of non-linear system of ordinary differential equations. Today, the generalized force - control (moment-control) can be determined on the basis of control theory. In the final analysis all these problems are solved by the Runge-Kutta's method. Power analysis makes it possible to calculate the strength of the mechanism of class IV parameters and to select the power for the desired drive unit. Thus, a fresh approach to make a simultaneous solution of kinematic, and dynamic problems of the mechanism of class IV is offered. The obtained results are easy to apply to mechanisms of high class with a larger number of closed contours. The importance of the fundamental scientific result presenting in brief the theory of mechanisms of high class lies in its practical application. The question always arises: how to use the theory actually proposed in a compressed form, and the unique properties of these mechanisms in the design of new devices and machines.

For the first time the programs on the Delphi's language calculate position, velocity in the mechanism of class IV with any desired accuracy.

The results of program on the position and velocity of links for the mechanism of class IV

Initial data:  $L_0 = 10\text{cm}$ ,  $L_1 = 2\text{cm}$ ,  $L_1^* = 2\text{cm}$ ,  $L_2 = 8,268\text{cm}$ ,  $L_3 = 5\text{cm}$ ,  $L_3^* = 5\text{cm}$ ,  $L_4 = 5,9133\text{cm}$ ,  $L_5 = 4\text{cm}$ ,  $L_6 = 0$ ,  $\alpha_1 = 60^\circ$ ,  $\alpha_3 = 30^\circ$ ,  $\varphi_0 = 0$ ,  $\varepsilon = 0,001$ ,  $\varphi_{5min} = 70^\circ$ ,  $\varphi_{5max} = 105^\circ$ ,  $\varphi_{3min} = 70^\circ$ ,  $\varphi_{3max} = 100^\circ$ ,  $h = 0,05^\circ$ ,  $\dot{\varphi}_5 = 0,01\text{rad/s}$ .

The program defines values of the angular coordinates of all remaining links at the possible ranges of variation  $\varphi_{3min} = 70^\circ \leq \varphi_3 \leq \varphi_{3max} = 100^\circ$ ,  $\varphi_{5min} = 70^\circ \leq \varphi_5 \leq \varphi_{5max} = 105^\circ$ . Separately we give the initial values of the angular coordinate of input link 5  $\varphi_5 = 90,0499999999989^\circ$  and of output link 3  $\varphi_3 = 90,0499999999989^\circ$  in accordance with which the movement of the mechanism starts. If we change the angular coordinate  $\varphi_5$  of input link 5  $90,0499999999989^\circ$  to  $90,2499999999988^\circ$

The position and velocity of change for output links 1-4 are listed in table 1 and table 2.

Table 1 – Angular coordinate of links for mechanism of class IV

$\varphi_1$	$\varphi_2$	$\varphi_3$	$\varphi_4$	$\varphi_5$
30.151212399452	-0.031675872130	90.0499999999989	12.928351949062	90.0499999999989
30.153170114784	-0.032123943447	90.0999999999989	12.907880756584	90.0999999999989
30.155201340299	-0.032593556243	90.1499999999989	12.887379206970	90.1499999999989
30.155693019626	-0.032636365534	90.1499999999989	12.879818673972	90.1999999999989
30.157800302286	-0.033107168760	90.1999999999989	12.859325664381	90.2499999999988

Table 2 – Velocity of links for mechanism of class IV

$\psi_1$	$\psi_2$	$\psi_3$	$\psi_4$
0,085501549459072	-0,0179259921115466	0,0241681781581009	-0,00757057156281362
0,0853804108253469	-0,0179268654072137	0,024138568162871	-0,00755344825048743
0,0852599951693558	-0,0179278751364108	0,0241091893026834	-0,00753641949441759
0,0852777526589473	-0,0179964249228941	0,0241643846455302	-0,00753728917467803
0,0852777526589473	-0,0179974850000152	0,0241350541017292	-0,00752029545151407

The computational experiment indicated that the mechanism of class IV has broad functionality. These mechanisms can be used in various fields of science and technics. These mechanisms can be used in the design of robots and cranes with high lifting capacity, mechanisms of departure chassis of a fighter aircraft landing at high speed on aircraft carriers, heavy transport and passenger aircrafts landing on the airfield, presses and hydraulic hammers at a significant rate of working body movements, and etc.

**Conclusion.** For the first time we make the following conclusions:

- a new direction is suggested in simultaneous calculation of kinematics and dynamics for mechanisms of high class on the basis of the differential-algebraic equations;
- methods and algorithms for determining the position and velocity of links in the mechanism of class IV are developed;
- a program for calculation of kinematic and dynamic parameters in the mechanism of class IV with any given accuracy is written.

#### REFERENCES

- [1] Assur L.V. Investigation of lower pair plane mechanisms in terms of structure and classification. M.: Publishing House of the USSR Academy of Sciences, 1952, 592 p. (in Rus.)
- [2] Artobolevsky I.I. The theory of mechanisms and machines. M.: Science, 1982, 640 p. (in Rus.)
- [3] Dzholdasbekov U.A. Graphical and analytical methods of analysis and synthesis of mechanisms of high class. Alma Ata: Science, 1983, 255 p. (in Rus.)
- [4] Gear C.W. The simultaneous numerical solution of differential-algebraic equations. IEEE Trans. Circuit Theory. 1971. CT.-18. P. 89-95.
- [5] Petzold L.R. A description of DASSL: A differential-algebraic system solver. Scient Comput Amsterdam: North-Holland, 1983. 65 p.
- [6] Shalashilin V.I., Kuznetsov E.B. The best continuation parameter // Reports RAS. 1994. Vol. 334, N 5. P. 566-568.
- [7] Sinchev B. Kinematic analysis of lever mechanisms // Reports of the National Academy of Sciences of Kazakhstan. 2003. N 3. P. 39-44 (in Rus.).

**Б. Синчев<sup>1</sup>, А. М. Муханова<sup>2</sup>**

<sup>1</sup>Международный университет информационных технологий, Алматы, Казахстан,

<sup>2</sup>Алматинский технологический университет, Алматы, Казахстан

#### ПРОЕКТИРОВАНИЕ УНИКАЛЬНЫХ МЕХАНИЗМОВ И МАШИН. I.

**Аннотация.** Эта работа посвящена разработке численных методов расчета кинематических и динамических параметров для проектирования механизма IV класса на основе уравнений кинематики и динамики. Кинематические и динамические модели этих механизмов описываются дифференциально-алгебраическими уравнениями. Эти уравнения относятся к сингулярным дифференциальным уравнениям. Впервые мы рассматриваем анализ динамики и кинематики механизмов высоких классов в совместной формулировке. Происходит кардинальный прорыв при переходе от механизма низшего класса к высокому классу для проектирования новых механизмов и машин. Предлагается новая концепция, основанная на методе Рунге-Кутты для механизмов высокого класса, направленная на решение кинематико-динамической модели. Разработаны методы, алгоритмы и программы для определения положения и скорости звеньев механизма класса IV с любой заданной точностью. Численный эксперимент показал огромное преимущество механизма IV класса для разработки нового механизма для машиностроения и робототехники.

**Ключевые слова:** кинематика, динамика, механизм высокого класса, машиностроение, робототехника.

**Б. Синчев<sup>1</sup>, А. М. Муханова<sup>2</sup>**

<sup>1</sup>Халықаралық ақпараттық технологиялар университеті, Алматы, Қазақстан,

<sup>2</sup>Алматы технологиялық университеті, Алматы, Қазақстан

### **БІРЕГЕЙ МЕХАНИЗМДЕРДІ ЖӘНЕ МАШИНАЛАРДЫ ЖОБАЛАУ. I.**

**Аннотация.** Жұмыс кинематика мен динамиканың теңдеулеріне негізделген IV класс жаңа механизмін жасау үшін кинематикалық және динамикалық параметрлерін есептеудің сандық әдістерін әзірлеуге арналған. Бұл механизмдердің кинематикалық және динамикалық үлгілері дифференциалдық алгебралық теңдеулермен сипатталады. Бұл теңдеулер сингулярлы дифференциалдық теңдеулерге жатады. Бірлескен тұжырымдамада жоғары деңгейлі механизмдердің динамикасын және кинематика анализін алғаш рет қарастырамыз. Жаңа механизмдер мен машиналарды жобалау үшін төменгі сынып механизмінен жоғары сыныпқа көшудің түбегейлі серпілісі бар. Кинематикалық-динамикалық модельді шешуге бағытталған жоғары дәрежелі механизмдер үшін Runge-Kutta әдісіне негізделген жаңа тұжырымдама ұсынылды. Сыныптың IV тетігінің кез-келген дәлдікпен байланыстарын және жылдамдығын анықтау әдістері, алгоритмдері және бағдарламалары әзірленді. Сандық эксперимент инженерлік және робототехниканың жаңа механизмін жасау үшін IV класты механизмнің үлкен артықшылығын көрсетті.

**Түйінді сөздер:** кинематика, динамика, жоғары дәрежелі механизм, машина жасау, робототехника.

#### **Сведения об авторах:**

Синчев Бахтгерей – д.т.н., профессор, Международный университет информационных технологий, e-mail: sinchev@mail.ru

Муханова Аксулу Мухамбеткалиевна – к.т.н., и.о. доцента, Алматинский технологический университет, e-mail: nuraksulu72@mail.ru

**Publication Ethics and Publication Malpractice  
in the journals of the National Academy of Sciences of the Republic of Kazakhstan**

For information on Ethics in publishing and Ethical guidelines for journal publication see <http://www.elsevier.com/publishingethics> and <http://www.elsevier.com/journal-authors/ethics>.

Submission of an article to the National Academy of Sciences of the Republic of Kazakhstan implies that the described work has not been published previously (except in the form of an abstract or as part of a published lecture or academic thesis or as an electronic preprint, see <http://www.elsevier.com/postingpolicy>), that it is not under consideration for publication elsewhere, that its publication is approved by all authors and tacitly or explicitly by the responsible authorities where the work was carried out, and that, if accepted, it will not be published elsewhere in the same form, in English or in any other language, including electronically without the written consent of the copyright-holder. In particular, translations into English of papers already published in another language are not accepted.

No other forms of scientific misconduct are allowed, such as plagiarism, falsification, fraudulent data, incorrect interpretation of other works, incorrect citations, etc. The National Academy of Sciences of the Republic of Kazakhstan follows the Code of Conduct of the Committee on Publication Ethics (COPE), and follows the COPE Flowcharts for Resolving Cases of Suspected Misconduct ([http://publicationethics.org/files/u2/New\\_Code.pdf](http://publicationethics.org/files/u2/New_Code.pdf)). To verify originality, your article may be checked by the Cross Check originality detection service <http://www.elsevier.com/editors/plagdetect>.

The authors are obliged to participate in peer review process and be ready to provide corrections, clarifications, retractions and apologies when needed. All authors of a paper should have significantly contributed to the research.

The reviewers should provide objective judgments and should point out relevant published works which are not yet cited. Reviewed articles should be treated confidentially. The reviewers will be chosen in such a way that there is no conflict of interests with respect to the research, the authors and/or the research funders.

The editors have complete responsibility and authority to reject or accept a paper, and they will only accept a paper when reasonably certain. They will preserve anonymity of reviewers and promote publication of corrections, clarifications, retractions and apologies when needed. The acceptance of a paper automatically implies the copyright transfer to the National Academy of Sciences of the Republic of Kazakhstan.

The Editorial Board of the National Academy of Sciences of the Republic of Kazakhstan will monitor and safeguard publishing ethics.

Правила оформления статьи для публикации в журнале смотреть на сайте:

[www.nauka-nanrk.kz](http://www.nauka-nanrk.kz)

**ISSN 2518-170X (Online), ISSN 2224-5278 (Print)**

<http://geolog-technical.kz/index.php/kz/>

*Верстка Д. Н. Калкабековой*

Подписано в печать 13.02.2018.  
Формат 70x881/8. Бумага офсетная. Печать – ризограф.  
12,0 п.л. Тираж 300. Заказ 1.